

1 **PHILIPPINE**
2 **NATIONAL**
3 **STANDARD**

PNS/BAFS xxx:2026
ICS 65.060.20

7
8
9
10
11
12
13
14
15
16
17
18
19
20
21 **Disc Plow for Four-Wheel**
22 **Tractors — Specifications**
23
24
25
26
27
28
29
30
31
32
33
34
35
36
37
38
39
40
41



BUREAU OF AGRICULTURE AND FISHERIES STANDARDS
BPI Compound, Visayas Avenue, Vasra, Quezon City 1128 Philippines

44
45
46

Trunkline: **(632) 928-8741 to 64 loc. 3301-3319**
E-mail: **bafs@da.gov.ph**
Website: **www.bafs.da.gov.ph**

47 **1 Scope**

48

49 This Standard specifies the requirements for the manufacture and performance
50 of a disc plow hitched to a four-wheel tractor with a minimum of 13.5 kW.

51

52 **2 Normative References**

53

54 The following documents are referred to in the text in such a way that some or all
55 their contents constitute the requirements of this document. The latest edition of
56 the referenced documents (including any amendments) applies.

57

58 Agricultural Machinery Testing and Evaluation Center (AMTEC)-University of the
59 Philippines Los Baños (UPLB). (2001). Agricultural machinery — Disc
60 Plow — Specifications (PNS/PAES 121:2001).

61 [https://amtec.ceat.uplb.edu.ph/wp-content/uploads/2020/06/PAES-121-
62 2000-converted.pdf](https://amtec.ceat.uplb.edu.ph/wp-content/uploads/2020/06/PAES-121-2000-converted.pdf)

63

64 Bureau of Agriculture and Fisheries Standards (BAFS)-Department of
65 Agriculture (DA). (2022). Technical means for ensuring safety —
66 Guidelines (PNS/BAFS 330:2022).

67

68 BAFS-DA. (2020). Production Machinery — Four-Wheel Tractor —
69 Specifications (PNS 301:2020)

70

71 BAFS-DA. (2024). After-sales service — Guidelines (PNS/BAFS 192:2024).

72

73 BAFS-DA. (2024). Methods of sampling for agricultural and biosystems power
74 and machinery — Guidelines (PNS/BAFS 391:2024).

75

76 BAFS-DA. (2024). Operator's manual for agricultural and biosystems power and
77 machinery — Guidelines (PNS/BAFS 390:2024).

78

79 BAFS-DA. (202x). Disc/Moldboard Plow — Methods of test (PNS/BAFS
80 xxx:2025).

81

82 Occupational Safety and Health Center (OSHC)-Department of Labor and
83 Employment (DOLE). (2020). Occupational safety and health standards.

84 [https://oshc.dole.gov.ph/wp-content/uploads/2020/02/OSH-Standards-
85 2020-Edition.pdf](https://oshc.dole.gov.ph/wp-content/uploads/2020/02/OSH-Standards-2020-Edition.pdf)

86
87
88
89
90
91
92
93
94
95
96
97
98
99
100
101
102
103
104
105
106
107
108
109
110
111
112
113
114
115
116
117
118
119
120
121
122
123
124
125
126
127

3 Terms and Definitions

For the purpose of this Standard, the following definitions shall apply. The preferred terms are written in bold type after the Clause number while admitted terms are listed in italicized type after the definition, which could be interchangeably used in interpreting the provisions of this Standard.

3.1

concave disc

circular concave steel plate used for cutting and inverting the soil (AMTEC-UPLB, 2001)

3.2

concavity

vertical distance measured from the lowest point to the center of the disc when its concave side is placed on a flat surface (AMTEC-UPLB, 2001)

3.3

disc angle

angle, in the soil surface plane, between a tool axis and a line, which is perpendicular to the direction of travel (AMTEC-UPLB, 2001)

admitted term: side angle

NOTE See Figure 2.

3.4

disc plow

implement with individually mounted concave disc blades which cut, partially or completely invert soil slices to bury surface material, and pulverize the soil (AMTEC-UPLB, 2001)

NOTE Blades are attached to the frame in a tilted position relative to the frame and to the direction of travel for proper penetration and soil displacement.

3.5

frame

structure on which the standards are fitted (AMTEC-UPLB, 2001)

NOTE See Figure 1.

128

3.6

129

hitch

130

portion of an implement designed to connect the implement to a power source (AMTEC-UPLB, 2001)

131

132

133

NOTE See Figure 1.

134

135

3.7

136

scraper

137

component which scrapes the soil adhering to the concave side of the disc (AMTEC-UPLB, 2001)

138

139

140

NOTE See Figure 1.

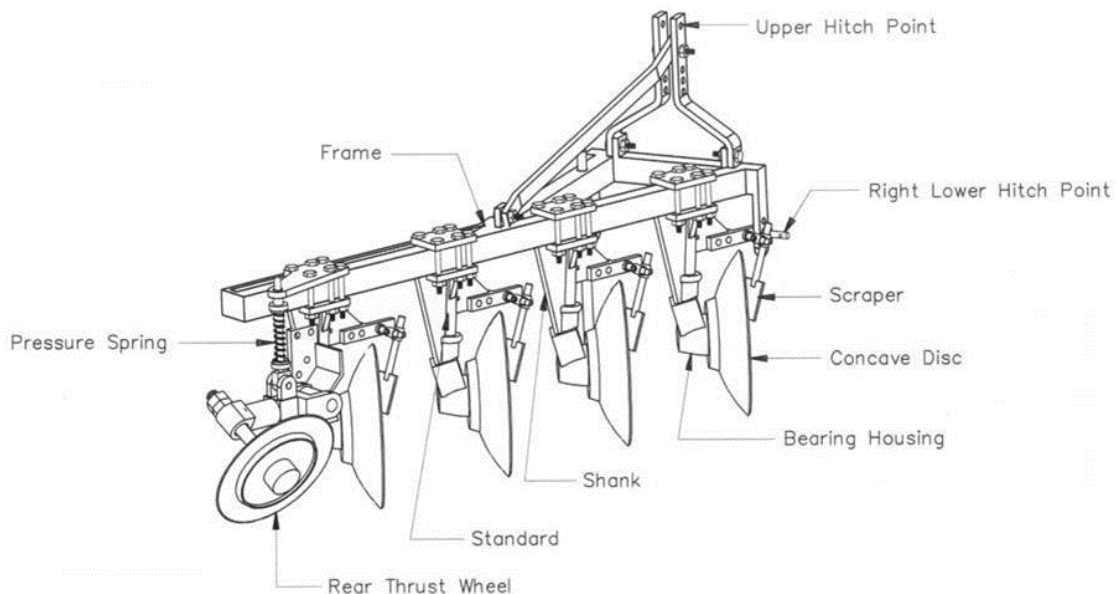

141

142

143

Figure 1. Disc plow and its components (AMTEC-UPLB, 2001)

144

145

NOTE See Figure 2.

146

147

3.8

148

standard

149

upright support which connects the shank to tillage implement frame (AMTEC-UPLB, 2001)

150

151

admitted term: beam

152

153

NOTE See Figure 1.

154
155
156
157
158
159
160
161
162

3.9
tilt angle

angle, in a vertical plane perpendicular to the direction of travel, between a tool axis and the soil surface (AMTEC-UPLB, 2001)

NOTE See Figure 2.

163
164
165

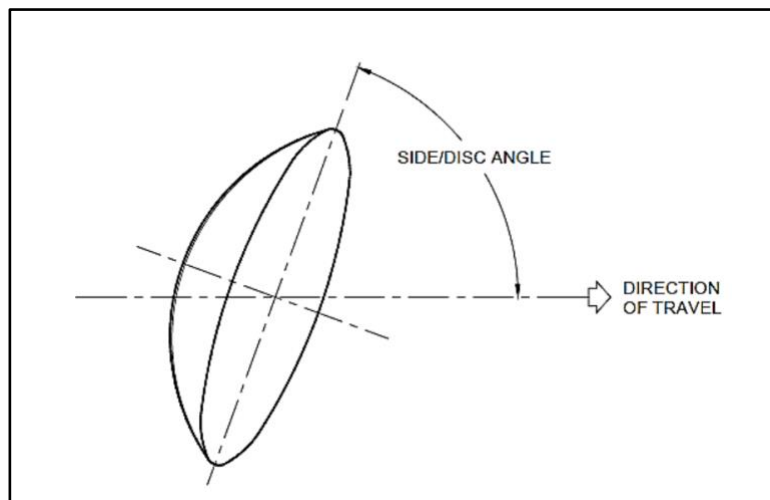

a. Top view

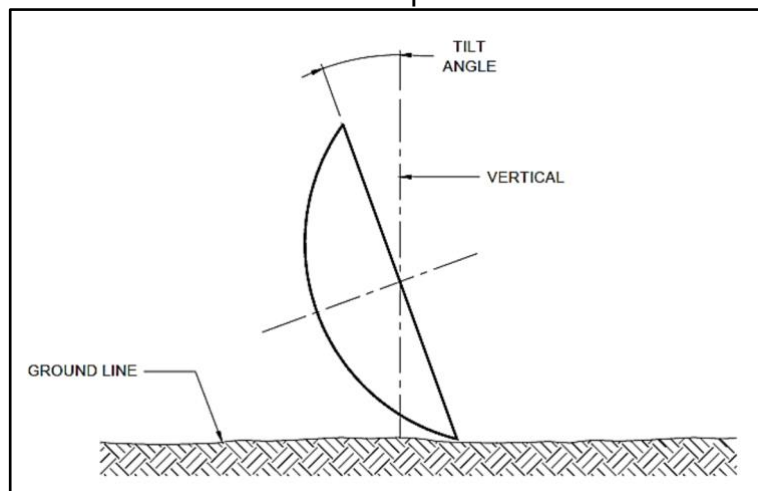

b. Side view

166
167
168
169
170
171

Figure 2. Top and side view of the disc and tilt angle (AMTEC-UPLB, 2001, modified)

172

173

3.10

174

depth of cut

175

one-third length of the disc diameter of the disc plow

176

177

4 Classification

178

179

4.1 One-way disc plow

180

181

Tractor-mounted or integral one-way disc plows are attached to the tractor by three-point hitch linkages and are fully carried by the tractor during transport as shown in Figure 3.

182

183

184

185

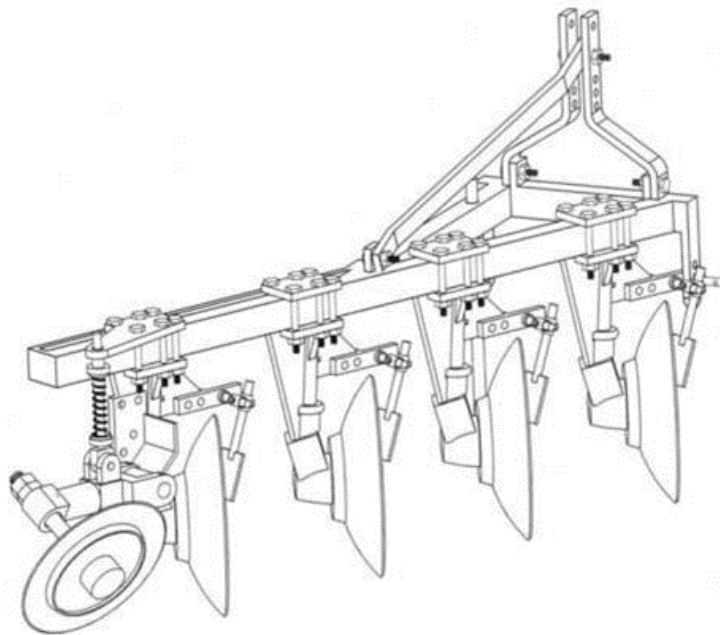

186

187

Figure 3. Tractor-mounted disc plow (AMTEC-UPLB, 2001)

188

189

190

191

4.2 Reversible disc plow

192

193

4.2.1 Tractor-mounted reversible disc plow

194

195

This plow is attached to the three-point hitch and is fully carried by the tractor in transport. This type is usually limited in size (2-4 discs) due to tractor front-end

196

197
198
199

stability and hydraulic- lift capacity as shown in Figure 4.

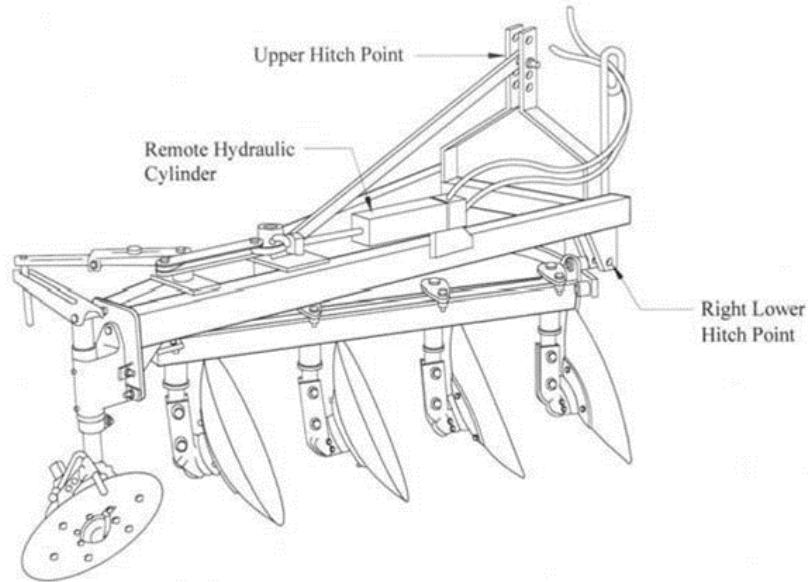

200
201
202

Figure 4. Tractor-mounted reversible disc plow (AMTEC-UPLB, 2001)

203
204
205

4.2.2 Semi-mounted reversible disc plow

206
207
208
209
210
211
212
213
214
215

Semi-mounted or semi-integral reversible disc plow is attached to the tractor's lower hitch points and is raised/lowered by the tractor hitch as well as a remote hydraulic cylinder on the rear transport wheel. On some of these plows, the rear wheel operates on the land and serves as a gauge wheel when plowing and as transport wheel (free to caster) when the plow is raised. The rear wheel is an attachment for converting a fully integral, reversible disc plow to semi-integral operation as shown in Figure 5.

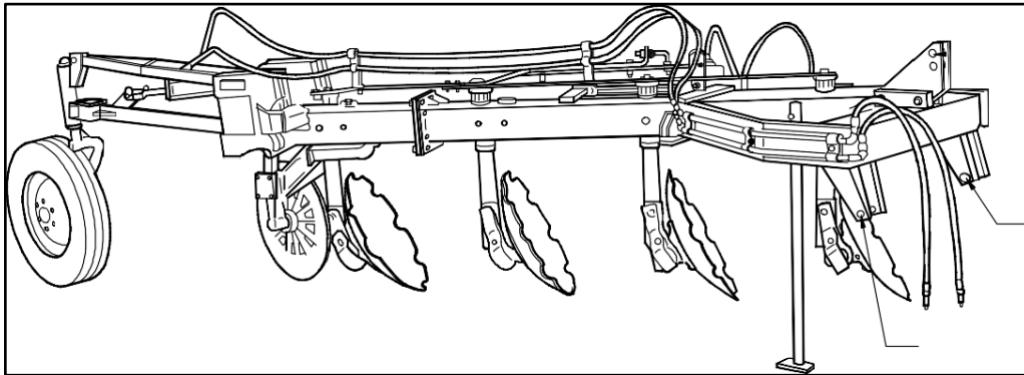

Figure 5. Semi-mounted reversible disc plow (AMTEC-UPLB, 2001)

5 Manufacturing Requirements

5.1 Mild steel shall be used in the manufacture of the frame, scraper, thrust wheel and hitch.

5.2 Carbon steel shall be used in the manufacture of hitch pin.

5.3 Carbon steel with at least 0.75% carbon content (e.g. AISI 1080) or alloy steel with at least 0.0005% boron content should be used in the manufacture of the disc blades (AMTEC-UPLB, 2001).

5.5 High carbon steel should be used in the manufacture of standard.

5.6 The thickness should be at least 4 mm.

5.7 The frame should be rigid and durable with no permanent deformation or noticeable cracks or defects during and after testing.

5.8 Each disc should be fastened securely to the hub with a minimum of four plow bolts, which are hammered, while the nuts are drawn securely.

5.9 If present, scrapers shall be adjustable and can be set in such a way that they shall not touch the face of the disc and shall be able to scrape the soil effectively.

5.10 Grease fittings for lubrication of bearings shall be provided. The bearings shall be properly aligned and provided with special dirt seals.

5.11 The hitch of the disc plow shall be compatible with the hydraulic system and the three-point hitch of the tractor specified in PNS/BAFS 301:2020 (Production Machinery — Four-Wheel Tractors — Specifications).

250

6 Performance Requirement

251

6.1 The maximum depth of cut of the plow specified by the manufacturer shall be attained.

254

6.2 During operation, the disc plow shall have the ability to plow throughout the complete depth of cut, and the computed actual field capacity shall achieve the declared field capacity.

255

6.3 The disc plow shall have no failure of components during test operation.

256

257

7 Safety, Workmanship, and Finish

258

7.1 The machine shall be free from defects that may be detrimental to its use.

259

7.2 The disc plow, except for disc blades, shall be free from sharp edges and surfaces that may harm the operator. All metal parts should be machine-bent, pressed, and cut, and all rough surfaces should be machine-finished and smoothed.

260

7.3 Except for disc blades, other uncoated metallic surfaces shall be free from rust and shall be painted properly.

261

7.4 Warning notices shall be provided in conformance with PNS/BAFS 330:2022 (Technical means for ensuring safety — Guidelines).

262

7.5 The use of disc plow in terms of the operator's exposure to permissible noise level shall conform to Annex A (Occupational safety and health standards - [Rule 1074.01– 1074.03]).

263

7.6 If the machine exceeds the noise level of 92 dB(A), an ear protective device shall be provided by the manufacturer.

264

265

8 After-sales Service Requirements

266

Requirements for after-sales services shall be in conformance with PNS/BAFS 192:2024 (After-sales service — Guidelines).

267

268

269

270

271

272

273

290
291
292
293
294
295
296
297
298
299
300
301
302
303
304
305
306
307
308
309
310
311
312
313
314
315
316
317
318
319
320
321
322
323
324
325
326
327
328
329

9 Maintenance and Operation (ADOPT)

9.1 Each unit of the disc plow shall be provided with a set of standard tools for operation and basic maintenance as prescribed by the manufacturer.

9.2 An operator's manual for the disc plow shall be provided in conformance with PNS/BAFS 390:2024 (Operator's manual for agricultural and biosystems power and machinery — Guidelines). The operator's manual shall include emphasis on the safety and health hazards, especially the use of basic personal protective equipment.

10 Sampling

The disc plow shall be sampled for testing in conformance with PNS/BAFS 391:2024 (Methods of sampling for agricultural and biosystems power and machinery — Guidelines) or other suitable method of selection validated by the testing authority.

11 Testing

The sampled disc plow shall be tested in conformance with PAES 132:2004 (Agricultural Machinery – Disc/Moldboard Plow – Methods of Test) or its latest issuance or other relevant standards for testing.

12 Markings and Labeling

12.1 Each unit of disc plow shall be engraved or embossed with the following information, either on the body or on a metal nameplate/s permanently attached at the most conspicuous place:

- a) Registered trademark of the manufacturer;
- b) Brand;
- c) Model;
- d) Serial number;
- e) Date of manufacture (optional); and
- f) Country of manufacture/origin (if imported) / “Made in the Philippines” (if manufactured in the country).

12.2 Reflectors shall be attached to the rear of the disc plow assembly for safety during

330 transport.

331

332 **12.3** During transport, For the trailed disc plow, it shall be fitted with a slow-moving
333 vehicle (SMV) emblem. The emblem shall be located at the rear of the plow with
334 the dimensional requirements as shown in Figure 6.

335

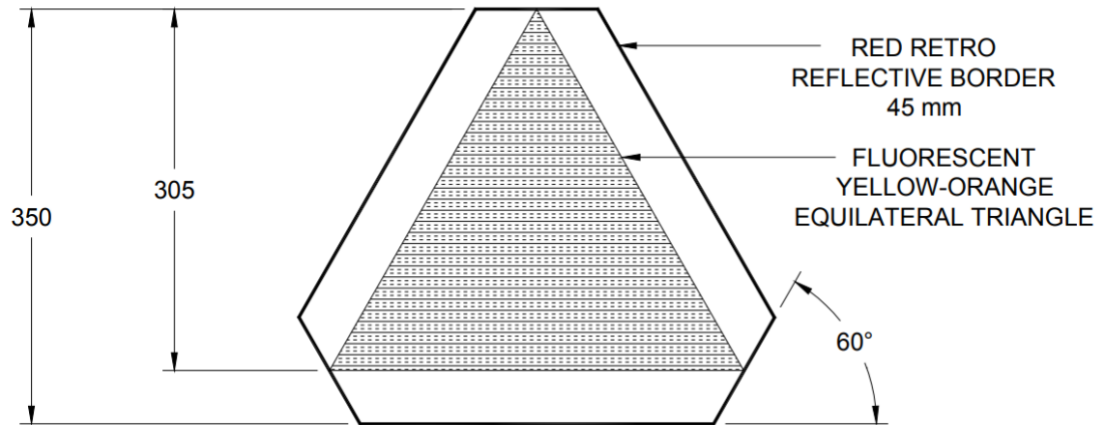

336

337 **Figure 6.** Slow-Moving Vehicle (SMV) Emblem (AMTEC-UPLB, 2004)

338

339

340 **12.4** During transport, For a mounted disc plow, it shall be fitted with at least one bright
341 colored reflector at the end of the frame.

342

343 **12.5** Other markings and labeling shall comply with the applicable regulations set by
344 the competent authority.

345

346

347

348

349

350

351

352

353

354

355

356

357

358

359

360

361

Annex A

362

(Informative)

363

364

Occupational safety and health standards (Rule 1074.01–1074.03)

365

366

A.1 Threshold limit values for noise

367

368

A.1.1 The threshold limit values refer to sound pressure that represents conditions under which it is believed that nearly all workers may be repeatedly exposed without adverse effect on their ability to hear and understand normal speech.

372

373

374

375

376

377

378

A.1.2 Feasible administrative or engineering controls shall be utilized when workers are exposed to sound levels exceeding those specified in Table A.1 hereof when measured on a scale of a standard sound level meter at slow response. If such controls fail to reduce sound within the specified levels, ear protective devices capable of bringing the sound level to permissible noise exposure shall be provided by the employer and used by the worker.

379

380

Table A.1. Permissible noise exposure (OSHC-DOLE, 2020)

Duration per day, h	Sound levels (slow response), dB(A)
8	90
6	92

4	95
3	97
2	100
1½	102
1	105
½	110
¼	115

381

382 **A.2 Permissible noise exposure**

383

384 **A.2.1** The values specified in Table A.1 apply to the total time of exposure per working
 385 day, regardless of whether this is one continuous exposure or a number of short-
 386 term exposures, but do not apply to impact or impulsive types of noise.

387

388 **A.2.2** If the variation in noise level involves maximum intervals of one second or less, it
 389 shall be considered as continuous. If the interval is over one second, it becomes
 390 impulse or impact noise.

391

392 **A.2.3** When the daily noise exposure is composed of two or more periods of noise
 393 exposure of different levels, their combined effect should be considered rather
 394 than the effect of each.

395

396 **A.2.4** If the sum of the fractions in Equation 1 exceeds one, then the mixed exposure
 397 should be considered to exceed the threshold limit value. C indicates the total
 398 time exposure at a specified noise level, and T indicates the total time of exposure
 399 permitted at the level. However, the permissible levels indicated in Table A.1 shall
 400 not be exceeded for the corresponding number of hours per day allowed. Noise
 401 exposures of less than 90 dB(A) are not covered by Equation 1.

402

$$X = \frac{C_1}{T_1} + \frac{C_2}{T_2} + \frac{C_3}{T_3} + \dots + \frac{C_n}{T_n} \quad (1)$$

403

404

405 **A.2.5** Exposures to impulsive or impact noise shall not exceed 140 dB(A) peak sound
406 pressure level (ceiling value).