

PHILIPPINE NATIONAL STANDARD

PNS/BAFS 417:2025
ICS 65.060.20

Subsoiler — Methods of Test



BUREAU OF AGRICULTURE AND FISHERIES STANDARDS
BPI Compound, Visayas Avenue, Vasra, Quezon City 1128 Philippines
Trunkline: **(632) 928-8741 to 64 loc. 3301-3319**
E-mail: **bafs@da.gov.ph**
Website: **www.bafs.da.gov.ph**

Subsoiler — Methods of Test
PNS/BAFS 417:2025
ICS 65.060.20

Copyright © 2025 by Bureau of Agriculture and Fisheries Standards

All rights reserved. The mention of specific organizations or products does not mean endorsement or recommendation from the Bureau of Agriculture and Fisheries Standards (BAFS) in preference to others of a similar nature that are not included. The BAFS encourages the reproduction and dissemination of the materials upon request. Applications for permissions to reproduce or disseminate these materials and all other queries should be addressed to the publisher

Published by:

Bureau of Agriculture and Fisheries Standards BAFS Building, BPI Compound,
Visayas Avenue, Diliman, Quezon City info.dabafs@gmail.com | bafs@da.gov.ph
(+632) 8928 8756 to 65 local 3301 – 3325

Suggested citation: Bureau of Agriculture and Fisheries Standards (BAFS)
Department of Agriculture (DA). (2025). Subsoiler — Methods of Test (PNS/BAFS
417:2025)

ISBN 978-621-455-620-5 (PDF downloadable)
ISBN 978-621-455-619-9 (Softbound/Paperback)

www.bafs.da.gov.ph

Foreword

The Department of Agriculture (DA)-Bureau of Agriculture and Fisheries Standards (BAFS) was mandated under Section 21 (Standards Development and Enforcement) particularly Rule 21.2 of the Implementing Rules and Regulations (IRR) for Republic Act (RA) No. 10601 (Agricultural and Fisheries Mechanization [AFMech] Law) to update existing standards under the Philippine Agricultural Engineering Standards (PAES) in collaboration with concerned agencies.

In 2022, the DA-Bureau of Agricultural and Fisheries Engineering (BAFE) endorsed a list of aged PNS/PAES/PABES with concerns to DA-BAFS to be considered for revision/amendment, which commenced after the standard was presented by the DA-BAFS during the DA-Philippine Council for Agriculture and Fisheries (PCAF)-National Sectoral Committee on Agriculture and Fishery Mechanization (CAFMech) Regular Meeting held on October 30, 2024. The development of the standard was prompted through a Table Review to validate and re-evaluate the relevance and applicability of terminologies against current scientific and technological developments, regulatory, and market requirements, and industry practices while ensuring alignment with related regional and international standards. Accordingly, PAES 150:2010 was included in the 2025 priority list for standardization to update its provisions in line with evolving industry practices and enhance clarity, consistency, and usability for stakeholders.

This Standard includes the following significant changes compared to the previous version:

- a) Modifications on the terms and definitions, and inclusion of subsoiler width and operating depth;
- b) Inclusion of principles of test;
- c) Particularization of the test site conditions and inclusion of soil hardness in test site assessment;
- d) Modification of the field performance test and inclusion of the suggested operational pattern;
- e) Inclusion of provisions related to noise level;
- f) Modification in the test report information; and
- g) Modification of all annexes and inclusion of a new annex related to soil analysis.

This document cancels and replaces PAES 150:2010 (Agricultural Machinery — Subsoiler — Methods of Test), which has been technically revised. This document was written in accordance with the formatting and editorial rules of the Standardization Guide (SG) No. 1 (Writing the PNS) and SG No. 5 (Agricultural and Fishery Machinery and Infrastructure — Guidelines) standard developed by the Standards Development Division (SDD) of the BAFS-DA.

Table of Contents

Foreword	ii
Table of Contents	iii
1 Scope	1
2 Normative References.....	1
3 Terms and Definitions	1
4 Principles of Test.....	6
5 Test Equipment and Materials.....	6
6 General Considerations.....	6
6.1 Test site conditions.....	6
6.2 Pre-test activities	7
6.3 Suspension/termination of test	7
7 Performance Test and Procedures.....	7
7.1 Field performance test.....	7
7.2 Operational pattern.....	8
7.3 Test trial	8
7.4 Measurement of initial data	8
7.5 Determination of draft (Optional)	9
7.6 Test for uniformity of depth of cut.....	10
7.7 Determination of wheel slip	11
7.8 Fuel consumption	12
7.9 Noise level.....	12
7.10 Data recording and observations.....	12
8 Formula	12
9 Test Report	13
Annex A.....	14
Annex B.....	15
Annex C	18
Annex D	20
Annex E.....	23
References.....	26

1 Scope

This Standard specifies the methods of test and inspection for a subsoiler. Specifically, it shall be used to:

- a) verify the mechanism, dimensions, materials, and accessories of the subsoiler and the list of specifications submitted by the manufacturer;
- b) determine the performance of the equipment; and
- c) report the results of the tests.

2 Normative References

The following documents are referred to in the text in such a way that some or all their contents constitute the requirements of this document. The latest edition of the referenced document (including any amendments) applies.

Agricultural Machinery Testing and Evaluation Center (AMTEC)-University of the Philippines Los Baños (UPLB). (2010). Agricultural machinery — Subsoiler — Methods of Test (PNS/PAES 150:2010).

<https://amtec.uplb.edu.ph/wp-content/uploads/2019/07/pns-paes-150-2010.pdf>

Bureau of Agriculture and Fisheries Standards (BAFS)-Department of Agriculture (DA). (2025). Subsoiler — Specifications (PNS/BAFS 416:2025).

3 Terms and Definitions

For the purpose of this Standard, the definitions given in PNS/BAFS 416:2025 (Subsoiler — Specifications) and the following shall apply:

3.1

draft

total force parallel to the direction of travel required to move the implement (AMTEC-UPLB, 2010).

3.2

drawbar power

power requirement of an implement being towed or pushed (AMTEC-UPLB, 2010)

3.3

effective field capacity

function of field speed, operating width, and field efficiency expressed in hectares per hour (AMTEC-UPLB, 2010)

3.4**field efficiency**

ratio of effective field capacity and theoretical field capacity of the machine

3.5**implement**

a non-self-propelled device designed to be attached, hitched, or connected to a tractor to perform an agricultural operation

3.6**operating depth**

depth at which the subsoiler's shanks penetrate the soil during operation

3.7**operating width**

the horizontal distance perpendicular to the direction of travel within which an implement performs its intended function; the distance obtained by multiplying the spacing by the total number of tillage tools (AMTEC-UPLB, 2010, *modified*)

NOTE See Figure 1.

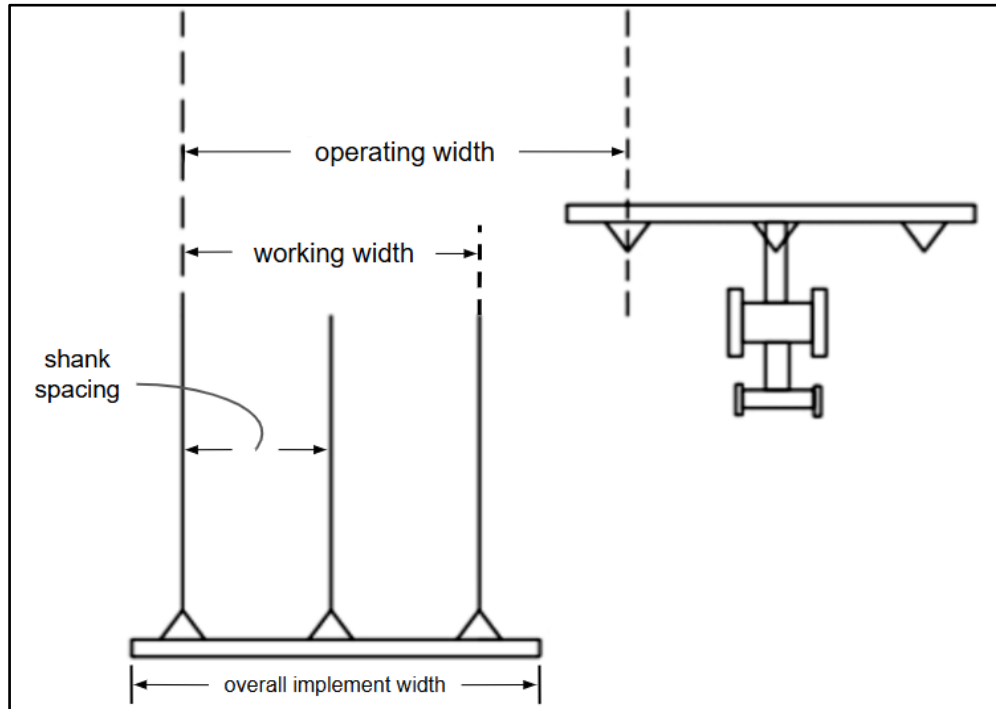

Figure 1. Illustration of a subsoiler showing the different types of width (adapted from AMTEC-UPLB, 2010)

3.8

overall implement width

distance between the vertical planes parallel to the median plane of the subsoiler, each plane touching the outermost point of the subsoiler on each respective side (AMTEC-UPLB, 2022, *modified*)

NOTE See Figure 2.

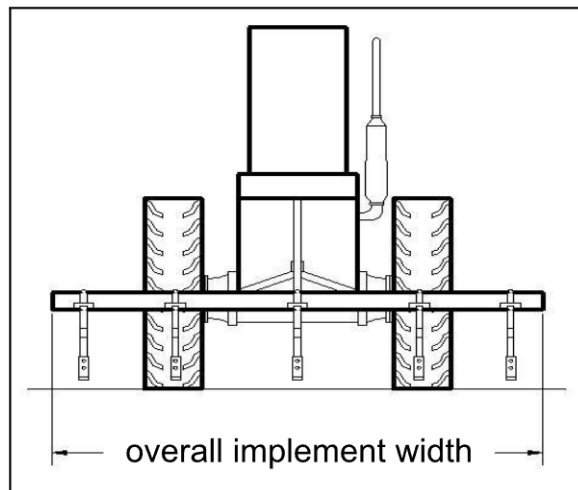

Figure 2. Overall implement width (adapted from AMTEC-UPLB, 2010)

3.9

subsoiler

distance between the tip of each wing (AMTEC-UPLB, 2010)

NOTE See Figure 3.

3.10

sweep angle

angle measured from the outer side of the wing in reference to the direction of travel (AMTEC-UPLB, 2010)

NOTE See Figure 3.

3.11

theoretical field capacity

function of speed and operating width expressed in hectares per hour (AMTEC-UPLB, 2010)

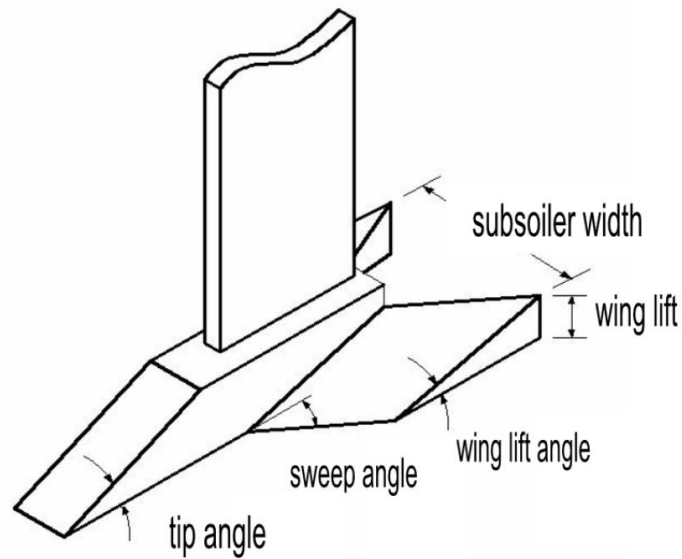

Figure 3. Ripper point characteristics (adapted from AMTEC-UPLB, 2010)

3.12

tip angle

angle formed by the top and underside of the ripper point (AMTEC-UPLB, 2010)

NOTE See Figure 3.

3.13

transport height

overall height of the implement measured from the topmost point to its lowest point (AMTEC-UPLB, 2010)

NOTE See Figure 4.

3.14

transport length

overall length of the implement measured from the terminal point of the implement to the mounting point (AMTEC-UPLB, 2010)

NOTE See Figure 4.

3.15

wing lift

length of the side of the wing opposite the wing lift angle (AMTEC-UPLB, 2010)

NOTE See Figure 3.

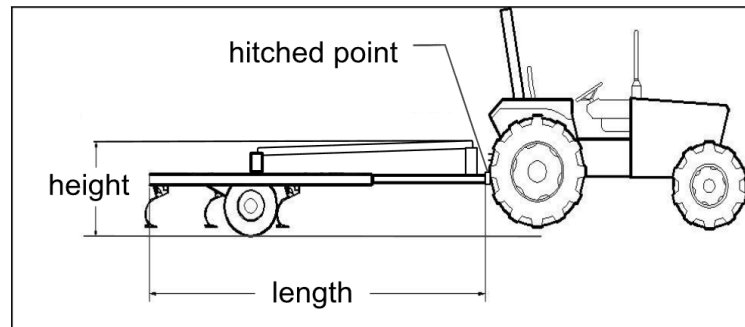

Figure 4. Transport height and length for four-wheel driven type (adapted from AMTEC-UPLB, 2010)

3.16

wing lift angle

angle measured between the horizontal and inclined sides of the wing (AMTEC-UPLB, 2010)

NOTE See Figure 3.

3.17

wing width

the side-to-side distance across the wings, measured straight (AMTEC-UPLB, 2025)

NOTE See Figure 5.

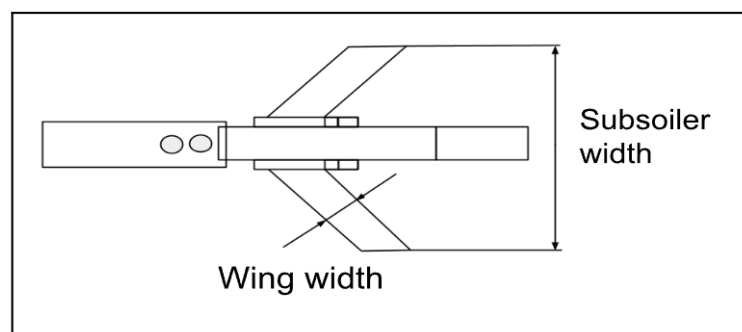

Figure 5. Wing width (adapted from Wang et al., 2019)

3.18

working width

horizontal distance perpendicular to the direction of travel within which an implement performs its intended function; distance between the outermost shanks of the subsoiler (AMTEC-UPLB, 2010)

NOTE See Figure 6.

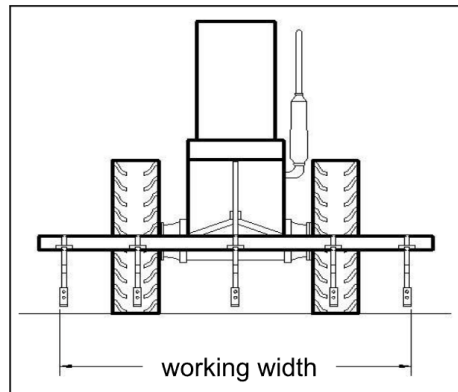

Figure 6. Working width (adapted from AMTEC-UPLB, 2010)

4 Principles of Test

The test shall be carried out to verify the actual specifications of the subsoiler. Its specifications shall be validated with PNS/BAFS 416:2025 (Subsoiler — Specifications).

5 Test Equipment and Materials

The test shall be carried out using the suggested minimum list of test equipment and materials needed as shown in Annex A (Minimum list of test equipment and materials). The test equipment and instruments to be used shall be calibrated regularly, physically checked for operation, and shall be cleaned before and after each test.

6 General Considerations

6.1 Test site conditions

6.1.1 The test site should be in an appropriate environment with ample space and suitable for safe working conditions.

6.1.2 The test shall be carried out on an unplowed dry and semi-dry field where the conditions of the field are to be recorded. The field shall have a loamy or clay soil texture. Soil texture and soil moisture content shall be determined using the recommended methods given in Annex B (Soil Analysis [Laboratory Method]).

6.1.3 The subsoiling operation shall be done in fields of not less than 1000 m² and should be rectangular in shape with sides in a ratio of 2:1. The headland of the field shall have at least 3 m in length.

6.1.4 The soil hardness should be measured using a cone penetrometer.

6.2 Pre-test activities

6.2.1 Preliminary adjustments

The subsoiler shall have undergone adjustments according to the manufacturer's recommendation prior to the conduct of testing to ensure the readiness of the machine.

6.2.2 Verification of specifications

The specifications claimed by the manufacturer and other physical details given in Annex C (Specifications of subsoiler) shall be verified. A stable and level surface shall be used as a reference plane for verification of dimensional machine specifications when fully assembled and ready for testing.

6.2.3 Preparation of the subsoiler for testing

The subsoiler shall be checked to ensure that the machine has been properly assembled and installed in conformance with the instructions of the manufacturer. The tractor to be used shall be compatible with the subsoiler in accordance with the manufacturer's specification of required power.

6.3 Suspension/termination of test

6.3.1 During the test run, if the subsoiling operation stops (due to minor breakdown or malfunction), the test shall be suspended. The test applicant shall be given an opportunity to make minor repairs or adjustments within a reasonable time.

6.3.2 The test shall be terminated if the machine is unable to continue operation after three attempts and all efforts have been exerted without replacing any major parts that can affect the performance of the machine. The test applicant has the option to terminate the test voluntarily at any stage of the testing process. In cases of a terminated test, a test report shall be prepared.

7 Performance Test and Procedures

7.1 Field performance test

7.1.1 The performance test shall be carried out to obtain actual data on the overall performance of the equipment.

7.1.2 The subsoiler shall be tested at the recommended depth settings of the manufacturer. The actual operating depth shall be noted and shall be compared with the recommended operating depth.

- 7.1.3** The tractor speed shall be determined according to the recommended depth setting. This can be done by recording the time required for the tractor to travel a 20 m distance in the field, as shown in Figure 7.

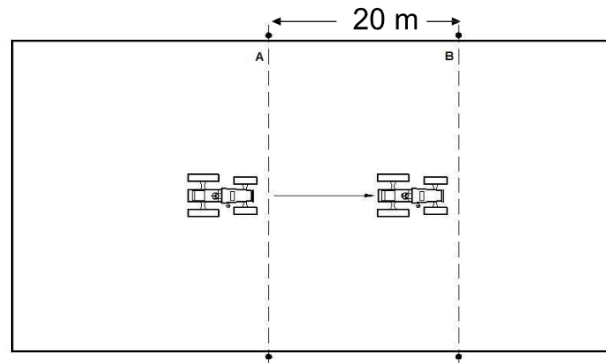

Figure 7. Points for speed test (adapted from AMTEC-UPLB, 2010)

- 7.1.4** The working width shall be determined by measuring the distance between the outermost shanks and shall be noted.
- 7.1.5** Field efficiency, effective field capacity, and drawbar power requirements of the implement shall be obtained using the formula in Annex D (Formula used for calculation and testing).
- 7.1.6** The subsoiler shall be tested at the recommended depth settings of the manufacturer, but shall not be less than 300 mm (AMTEC-UPLB, 2010)

7.2 Operational pattern

Field capacity and field efficiency are influenced by the field operational pattern. The operational pattern shall follow the continuous pattern turn strips each end as shown in Figure 8.

7.3 Test trial

The test shall be conducted with at least three test trials. Test data shall be measured for each pass.

7.4 Measurement of initial data

The initial data, such as field area, soil type, soil hardness, and soil moisture content, shall be obtained and recorded in Annex E (Performance test data sheet) before the test operation

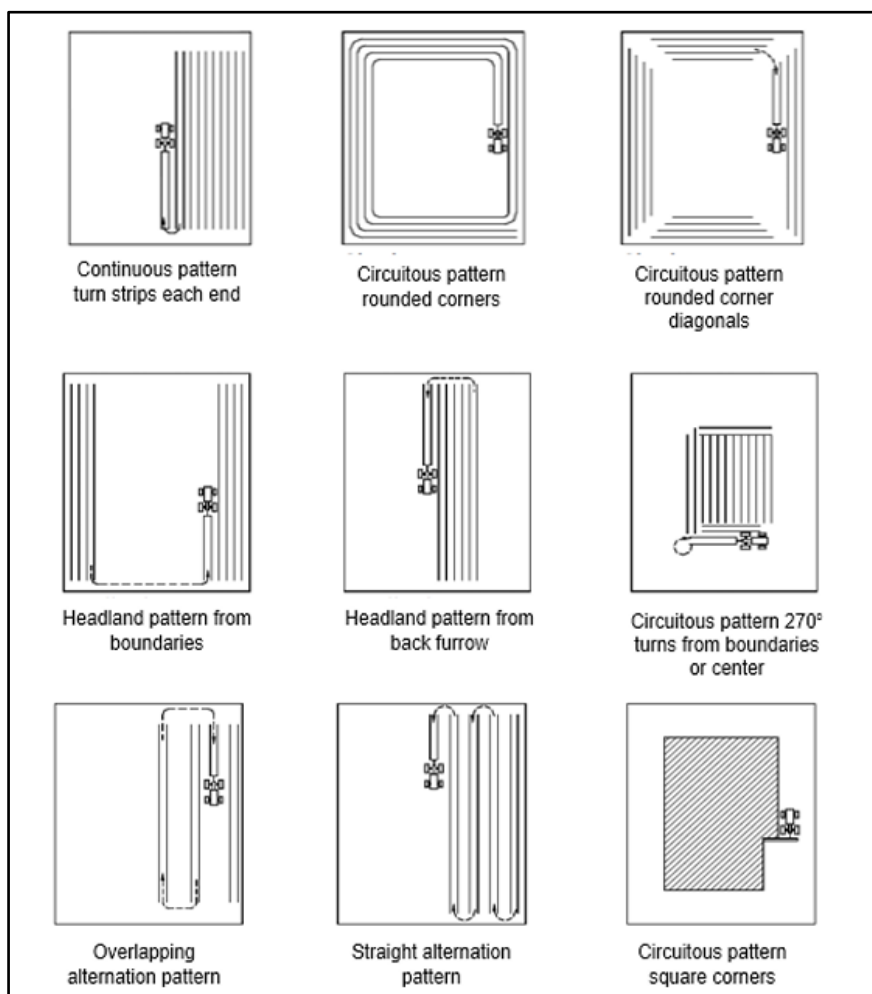

Figure 8. Field operational patterns (Regional Network for Agricultural Machinery [RNAM],1995)

7.5 Determination of draft (Optional)

7.5.1 A spring, hydraulic, or strain-gauge type dynamometer shall be attached to the front of the tractor on which the implement is mounted. Another auxiliary tractor shall pull the implement-mounted tractor through the dynamometer in neutral gear but with the implement in its operating position as shown in Figure 9. The draft in the measured distance of 20 m as well as the time it takes to traverse it shall be recorded. On the same field, the draft in the same distance shall be recorded while the implement is lifted above the ground. The difference in the draft readings shall yield the draft of the implement.

7.5.2 The total test time shall be obtained (determined) by acquiring (measuring) the total time required to finish (complete) subsoiling the test field. Non-productive time (e.g., headland turns) shall be recorded separately. The productive time shall be recorded (calculated) by deducting (subtracting) the non-productive time from the total test time.

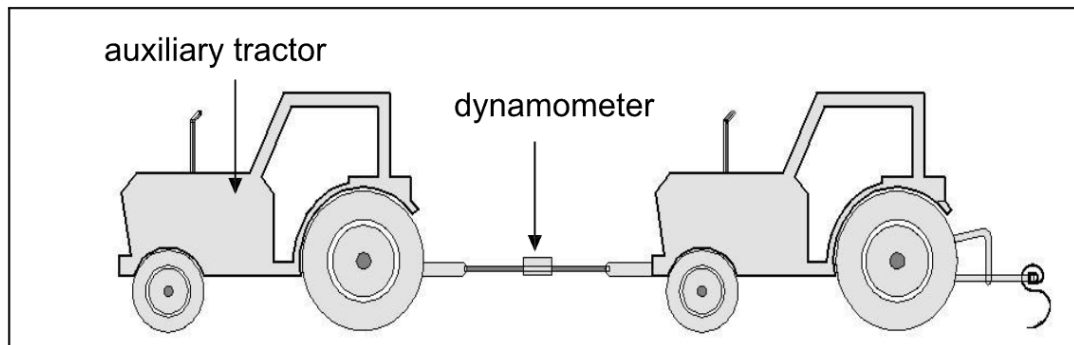

Figure 9. Position of tractors for draft measurement (adapted from AMTEC-UPLB, 2010)

7.6 Test for uniformity of depth of cut

- 7.6.1** Two points in the field passed shall be marked using pegs (points A and B). The distance between these points shall be 20 m. Every two meters, a marking peg shall be placed as shown in Figure 10.

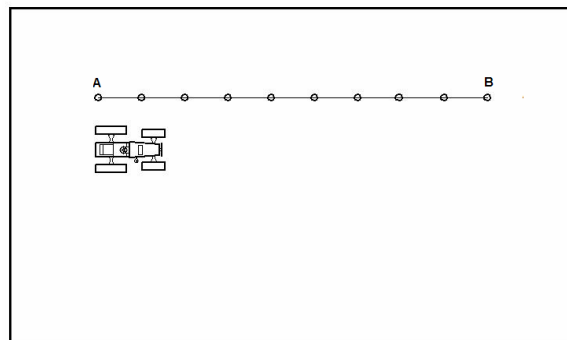

Figure 10. Soil strips marking for operating depth analysis (adapted from AMTEC-UPLB, 2010)

- 7.6.2** The operating depth of the subsoiler shall be set. The subsoiler shall be operated along the marked strips as shown in Figure 10. These strips of soil shall be observed.
- 7.6.3** The depth of cut for each strip shall be measured and shall be recorded as shown in Figure 11.
- 7.6.4** The mean depth and the percent error for the mean depth shall be computed using the formula in Annex E (Formula used for calculation and testing).

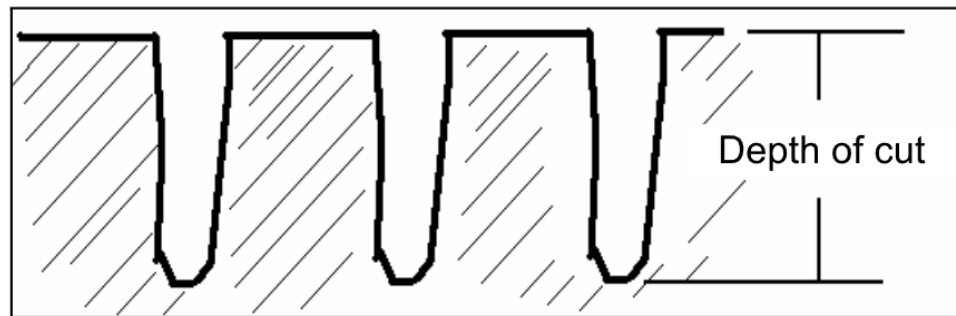

Figure 11. Depth of cut (adapted from AMTEC-UPLB, 2010)

7.7 Determination of wheel slip

7.7.1 The percentage of wheel slip shall be obtained by recording the difference of the distance traveled without load and the distance traveled with the implement attached. A mark shall be placed on the wheel of the tractor as shown in Figure 12. The tractor shall be allowed to move forward up to 10 revolutions of the marked wheel under no load (A). The distance shall be measured and recorded. On the same surface, the tractor shall be allowed to move forward with the implement attached. After the same number of revolutions, the distance traveled shall be measured and recorded (B). The percentage of wheel slip shall then be computed using the formula in Annex E (Formula used for calculation and testing).

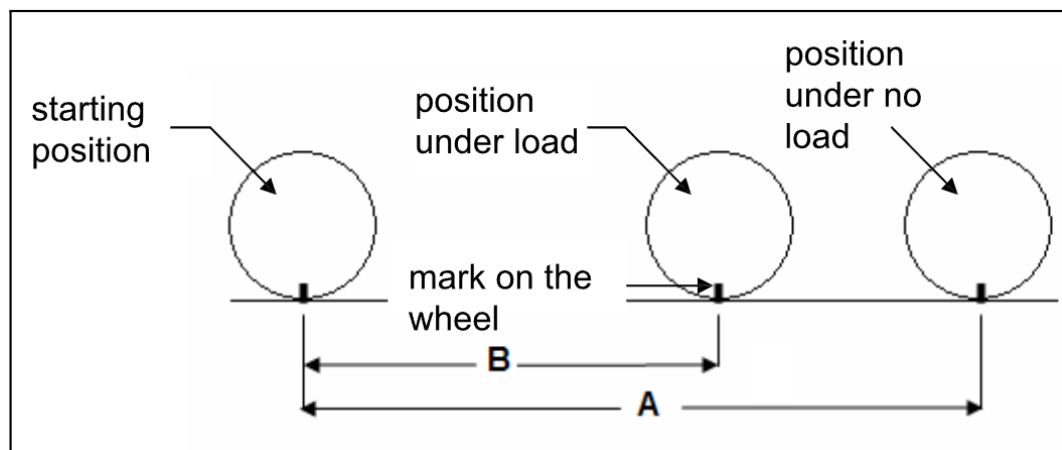

Figure 12. Measuring of wheel slip (as adapted from AMTEC-UPLB, 2010)

7.7.2 Condition of the subsoiler after the test shall be compared to its initial condition.

7.8 Fuel consumption

The energy consumption of the engine of the prime mover of the subsoiler may be obtained using any of the following methods:

a) Refilling the fuel tank

The fuel consumption of the machine shall be obtained by measuring the volume of fuel refilled after the test. The tank shall be filled to full capacity before and after each trial. The total operating time of the machine shall be recorded. The fuel consumption rate shall be computed using the formula specified in Annex E (Formula used for calculation and testing).

b) Using a fuel consumption meter

The fuel consumption shall be obtained by connecting the engine fuel line to a fuel consumption meter. The total time to consume a given volume of fuel (e.g., 10 mL, 15 mL) shall be recorded. The fuel consumption rate shall be computed using the formula specified in Annex E (Formula used for calculation and testing).

7.9 Noise level

7.9.1 The sound emitted by the four-wheel tractor used during the subsoiling operation shall be measured 50 mm away from the ear level of the operator/s using a sound level meter, expressed in decibel [dB (A)].

7.9.2 There shall be a minimum of five observations in a two-minute interval. Before collecting data, it should be ensured that the operations and other functional characteristics of the subsoiler have stabilized. The time or recording shall be properly spaced during the whole duration of the test trial.

7.10 Data recording and observations

All data and information during the test shall be recorded using the record sheet provided in Annex D (Performance test data sheet). Necessary observations and other parameters to be taken during the field performance test should be recorded on this sheet.

8 Formula

The formulas provided in Annex E (Formula used for calculation and testing) shall be used.

9 Test Report

The test report shall include the following information in the given order:

- a) Name of testing agency;
- b) Test report number;
- c) Title;
- d) Summary of results;
- e) Purpose and scope of test;
- f) Methods of test;
- g) Description of the machine;
- h) Specifications;
- i) Results;
- j) Observations (include pictures); and
- k) Names, signatures, and designation of test engineers and assisting technicians.

Annex A
(Informative)

Minimum list of test equipment and materials

	Test equipment and materials	Quantity
A.1	Test equipment and instruments	
A.1.1	Sound level meter Range: 30 dB(A) to 130 dB(A) Resolution: 0.1 dB(A)	1
A.1.2	Digital stopwatch (Timer) Resolution: 0.1 sec	1
A.1.3	Measuring tape Minimum length: 10 m	1
A.1.4	Camera	1
A.1.5	Caliper (Resolution: 0.01 mm)	1
A.1.6	Weighing scale	1
A.1.7	Graduated cylinder	1
A.1.8	Computer	1
A.1.9	Fuel consumption meter	1
A.1.10	3-inch-diameter aluminum ring	1
A.1.11	Wood block or plastic insertion cap	1
A.1.12	Rubber mallet or weight	1
A.1.13	Flat-bladed knife	1
A.1.14	18-inch metal rod	1
A.1.15	Resealable plastic bags	6
A.1.16	Width and depth gauge	1
A.1.17	Four-wheel tractor or Two-wheel tractor	1
A.1.18	Convection oven or soil moisture meter	1
A.1.19	Electronic balance Capacity: 1kg	1
A.1.20	Sieve Sizes: 2 mm, 0.05 mm, and 0.0002 mm	3
A.2	Test materials	
A.2.1	Marking pegs	20

Annex B
(Normative)

Soil analysis (Laboratory method)

B.1 Soil Texture Determination

B.1.1 This test is carried out to analyze the soil samples taken during the performance test to determine the soil texture of the test area.

B.1.2 Three soil samples shall be taken from the test area. Each soil sample shall be weighed and recorded.

B.1.3 Each soil sample shall then be passed through a series of sieves.

B.1.4 The type of soil (i.e. sand, silt and clay) that is retained in a particular sieve shall be weighed. (see Table C.1)

Table C.1. Grain Size for Different Soil Types (AMTEC-UPLB, 2004)

Soil type	Grain size, mm	Remarks
Sand	2.0 – 0.05	Passed through the 2 mm sieve but retained by the 0.05 mm sieve
Silt	0.05 – 0.002	Passed through the 0.05 mm sieve but retained by the 0.002 mm sieve
Clay	< 0.002	Passed through the 0.002 mm sieve

B.1.5 The relative composition of each soil type expressed in percent shall be computed as follows:

$$\% \text{ Sand} = \frac{\text{Weight of sand}}{\text{Total weight of soil}} \times 100$$

$$\% \text{ Silt} = \frac{\text{Weight of silt}}{\text{Total weight of soil}} \times 100$$

$$\% \text{ Clay} = \frac{\text{Weight of clay}}{\text{Total weight of soil}} \times 100$$

B.1.6 The relative composition of the sand, silt and clay shall be used to determine the soil type using the soil texture triangle as shown in Figure 13.

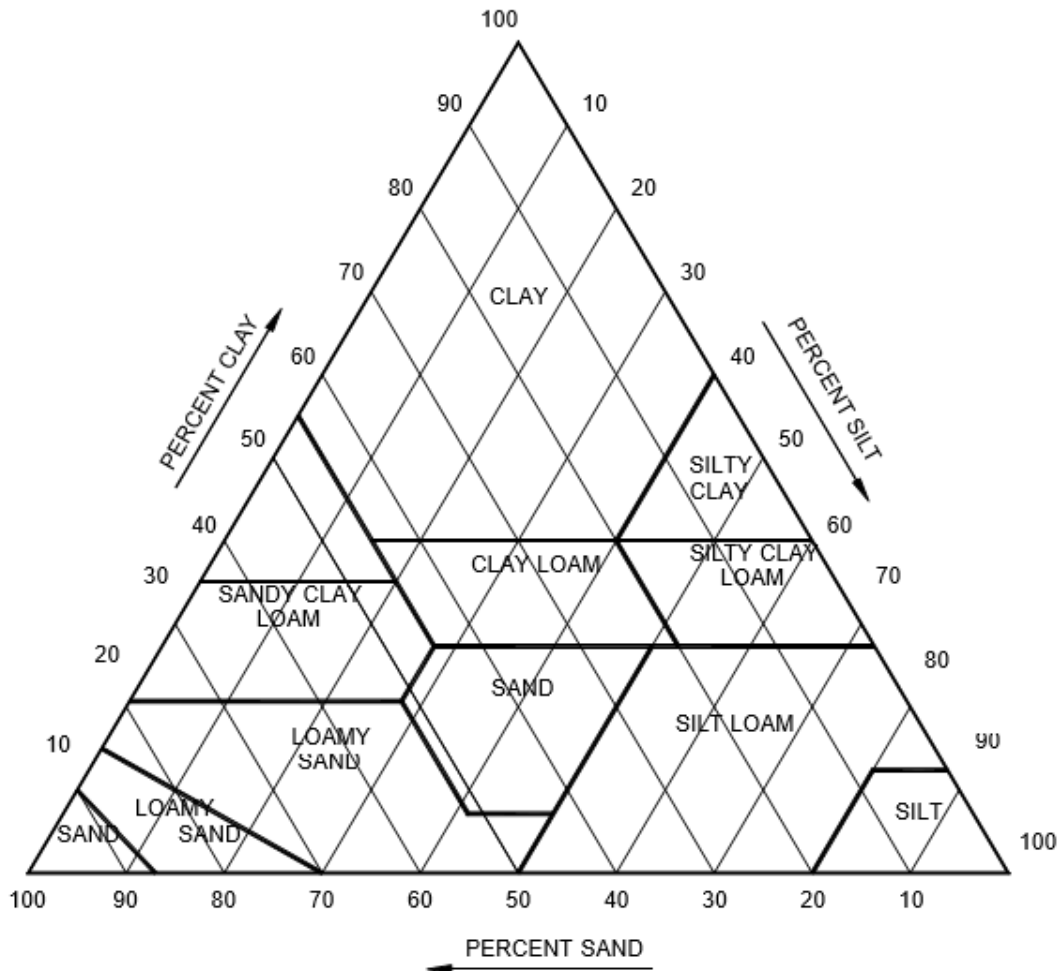

Figure 13. Soil texture triangle showing relative composition of texture class (Soil Survey Division Staff, 1993)

B.2 Soil Moisture Content Determination (Oven method)

B.2.1 This test is carried out to analyze the soil samples taken during the performance test to determine the soil moisture of the test area.

B.2.2 Three core soil samples in at least three different locations of test plots shall be taken randomly from the test area. Each soil sample shall be weighed and recorded as the initial weight.

B.2.3 The samples shall be dried using a convection oven maintained at 105°C for at least eight hours.

B.2.4 The oven-dried sample shall then be placed in a desiccator. Each soil sample shall be weighed and recorded as oven-dried weight.

B.2.5 The soil moisture (% dry weight basis) shall be computed as follows:

$$\text{Soil Moisture (\%dry weight basis)} = \frac{W_i - W_f}{W_f} \times 100$$

where:

W_i is the initial weight of the soil, kg

W_f is the oven-dried (final) weight of the soil, kg

B.2.6 The soil moisture content can also be measured using a soil moisture meter.

Annex C
(Normative)
Specifications of subsoiler

Name of Applicant : _____
Address : _____
Tel. No. : _____

GENERAL INFORMATION

Make : _____ Type : _____
Serial No. : _____ Brand and Mode : _____
Country of Manufacture/Origin : _____ Date of Manufacture : _____
Testing Agency : _____ Test Engineer : _____
Location of Test : _____ Date of Test : _____

No.	Item	Manufacturer's specification	Verification by the testing agency
C.1	Overall dimensions		
C.1.1	Transport height, mm		
C.1.2	Transport length, mm		
C.1.3	Implement width, mm		
C.1.4	Weight, kg		
C.1.5	Working width, mm		
C.2	Main frame		
C.2.1	Material		
C.2.2	Length, mm		
C.2.3	Width, mm		
C.2.4	Thickness, mm		
C.3	Shank assembly		
C.3.1	Wear shin		
C.3.1.1	Material		
C.3.1.2	Width, mm		
C.3.2	Shank		
C.3.2.1	Material		
C.3.2.2	Dimensions, mm		
C.3.2.3	Ground clearance, mm		
C.3.2.4	Stem angle, degrees		
C.3.2.5	Type		
C.3.2.6	Number of shanks		
C.3.3	Ripper point		

C.3.3.1	Material		
C.3.3.2	Type		
C.3.3.3	Dimensions, mm		
No.	Item	Manufacturer's specification	Verification by the testing agency
C.3.3.4	Tip angle, degrees		
C.3.3.5	Sweep angle (for winged degrees)		
C.4	Transverse toolbar		
C.4.1	Material		
C.4.2	Length, mm		
C.4.3	Width, mm		
C.4.4	Distance from the hitch, mm		
C.5	Gauge wheels (if present)		
C.5.1	Diameter, mm		
C.5.2	Adjustments		
C.6	Mounting details		
C.7	Tractor required		
C.7.1	Type		
C.7.2	Recommended traveling speed, kph		
Ce.7.3	Engine power, kW		

Annex D
(Normative)

Performance test data sheet

D.1	Test site conditions	Remarks
D.1.1	Area of plot, m ²	
D.1.2	Soil type (clay, clay loam, sandy, etc.)	
D.1.3	Soil texture (fine, medium, coarse)	
D.1.4	Soil moisture content (% d.b.)	
D.1.5	Soil hardness (kg/cm ²)	

D.2 Field performance										
D.2.1 Operating width, m										
D.2.2 Width of cut, m										
D.2.3 Manufacturer's recommended setting, mm	Trials									Average
	1			2			3			
D.2.4 Tractor speed, kph										
D.2.5 Operating time, h	Trials									Average
	1			2			3			
	Test time	Non-productive	Test time	Non-productive	Test time	Non-productive	Test time	Non-productive	Productive time	
D.2.6 Fuel consumed, mL										
	Trials									Average
	1			2			3			
D.2.7 Field efficiency, %										
D.2.8 Effective field capacity, ha/h										
D.2.9										
	Trials									Average

Draft, N (optional)	1			2			3			
D.2.10 Drawbar power, kW (optional)										
D.2.11 Depth of cut analysis										
Depth of cut preset, mm:										
Strip, m	0-2	2-4	4-6	6-8	8-10	10-12	12-14	14-16	16-18	18-20
Depth, mm										
Mean depth, mm:										
Percent error, %:										
D.2.12 Percentage of wheel slip (% W.S.)										
Trials									Ave, %	
1			2			3				
A(m)	B(m)	% W.S.	A(m)	B(m)	% W.S.	A(m)	B(m)	% W.S.		

D.3 Other observations

D.3.1 Ease of mounting/dismounting

D.3.2 Accessibility of grease points

D.3.3 Number of shanks deformed after test

D.3.4 Number of shovels detached after test

D.3.5 Cracks on welded parts

D.3.6 Detached welded parts

D.3.7 Loosened bolts

D.3.8 Miscellaneous

Annex E
(Normative)

Formula used for calculation and testing

E.1 Total distance travelled

$$D = \frac{A}{S}$$

where:

D is the total distance traveled, m
 A is the area of plot, m²
 S is the effective working width, m

E.2 Effecting working width

$$S = \frac{W}{2N}$$

where:

S is the effective working width, m
 W is the width of plot, m
 $2N$ is the number of passes

E.3 Effective area accomplished

$$E = w \times D$$

where:

E is the effective area accomplished, m²
 w is the operating width, m
 D is the total distance traveled, m

E.4 Drawbar power

$$P = \frac{D \times S}{3.6}$$

where:

- P is the drawbar power required for the subsoiler, kW
 D is the draft force required to move the subsoiler, kN
 S is the speed of tractor, kph

E.5 Percent error for mean depth

$$\%error = \frac{|D_m - D_p|}{D_p} \times 100$$

where:

- $\%error$ is the percent error, %
 D_m is the mean depth, mm
 D_p is the theoretical depth, mm

E.6 Percentage of wheel slip

$$\%W.S. = \frac{A - B}{A} \times 100$$

where:

- $\%W.S.$ is the percent of wheel slip, %
 A is the distance traveled by the tractor under no load after a given number of revolutions, m
 B is the distance traveled by the tractor with implement attached after a given number of revolutions, m

E.7 Theoretical field capacity

$$tfc = \frac{w \times S}{10}$$

where:

- tfc is the theoretical field capacity, ha/h
 w is the operating width, m
 S is the speed of operation, kph

E.8 Actual field capacity

$$afc = \frac{0.006A_e}{t}$$

where:

afc is the actual field capacity, ha/h
 t is the time used during the operation, min

E.9 Field efficiency

$$\varepsilon_f = \frac{afc}{tfc} \times 100$$

where:

ε_f is the field efficiency, %

E.10 Fuel consumption rate

$$F_t = \frac{V}{t}$$

where:

F_t is the fuel consumption rate, L/h
 V is the total volume of fuel consumed, L
 t is the total operating time, h

E.11 Effective fuel consumption rate

$$F_e = \frac{10,000V}{E}$$

where:

F_e is the effective fuel consumption rate, L/ha
 V is the volume of fuel consumed, L
 E is the effective area covered, m²

References

- Agricultural Machinery Testing and Evaluation Center (AMTEC)-University of the Philippines Los Baños (UPLB). (2001). Agricultural machinery — Four-Wheel Tractor — Methods of Test (PAES 119:2001). <https://amtec.uplb.edu.ph/wp-content/uploads/2019/07/119a.pdf>
- Agricultural Machinery Testing and Evaluation Center (AMTEC)-University of the Philippines Los Baños (UPLB). (2004). Agricultural machinery — Disc Harrow — Methods of Test (PAES 133:2004). <https://amtec.uplb.edu.ph/wp-content/uploads/2019/07/paes-133.pdf>.
- Agricultural Machinery Testing and Evaluation Center (AMTEC)-University of the Philippines Los Baños (UPLB). (2010). Agricultural machinery — Subsoiler — Methods of Test (PNS/PAES 150:2010). <https://amtec.uplb.edu.ph/wp-content/uploads/2019/07/pns-paes-150-2010.pdf>
- Bureau of Agriculture and Fisheries Standards (BAFS)- Department of Agriculture (DA). (2025). Subsoiler — Specifications (PNS/BAFS 416:2025).
- Regional Network for Agricultural Machinery (RNAM). (1995). RNAM Test codes and procedures for farm machinery (2nd Ed). United Nations.
- Soil Survey Division Staff. (1993). *Soil survey manual* (U.S. Department of Agriculture Handbook No. 18). U.S. Government Printing Office.
- Wang, X., Gao, P., Yue, B., Shen, H., Fu, Z., Zheng, Z., Zhu, R., & Huang, Y. (2019). Optimisation of installation parameters of subsoiler' wing using the discrete element method. *Computers and Electronics in Agriculture*, 162, 523–530. <https://doi.org/10.1016/j.compag.2019.04.044>

**Department of Agriculture (DA)
Bureau of Agriculture and Fisheries Standards (BAFS)**

**Technical Working Group (TWG) for the Philippine National Standard (PNS) on
Subsoiler — Methods of Test**

Chairperson

Ampo, Mel Vincent, ABE
Valencia, Ronnie, ABE

**Center of Agri-Fisheries and Biosystems Mechanization (BIOMECH)-
University of the Philippines Los Baños (UPLB)**

Vice Chairperson

Fajardo, Arthur, PhD
Reyes, Marie Jehosa, ABE

Agricultural Machinery Testing and Evaluation Center (AMTEC)-UPLB

Members

- | | | | |
|---|---|----|--|
| 1 | Bontogon, Abbygail, ABE | 10 | Ranches, Mark Angelo, ABE |
| 2 | Bore, Jefferson, ABE | 11 | Zubia, Omar, PhD |
| | Bureau of Agricultural and Fisheries Engineering (BAFE)-DA | | Institute of Agricultural and Biosystems Engineering (IABE)-UPLB |
| 3 | Bentulan, Em, ABE | 12 | Falic, Ma. Eden, ABE |
| 4 | Melendez, Peachie, ABE | 13 | Tamayo, Rodolfo |
| | Philippine Council for Agriculture and Fisheries (PCAF)-DA | | Agricultural Machinery Manufacturers and Distributors Association (AMMDA), Inc. |
| 5 | Miano, Joey, ABE | 14 | Mangaoang, Crestituto, ABE |
| | Philippine Rice Research Institute (PhilRice)-DA | | Philippine Society of Agricultural and Biosystems Engineering (PSABE), Inc. |
| 6 | Aguilar, Jan-Jan, ABE | 15 | Espinar, Henry, ABE |
| 7 | Jardin-Millare, Triniza, ABE | 16 | Mora, Peter Paul, ABE |
| | DA Regional Field Office (RFO) - CALABARZON | | DA RFO- Bicol |
| 8 | Balao, Katherine, ABE | | |
| 9 | Eslava, Eva, ABE | | |
| | DA RFO- Cagayan Valley | | |

Management Team

Lanuza, Alpha, DVM /
Hernandez, Gari Pellinor, DVM /
Marimla, Clark Gerald, ABE
Olarte, Madellaine, ABE
Villacentino, Sheila Mae
BAFS-DA

Adviser

Mandigma, Mary Grace, PFT
BAFS-DA

Illustration Contributors

Faisal, Arham
Mandi, Shalimar
Mindanao State University



BUREAU OF AGRICULTURE AND FISHERIES STANDARDS

**BPI Compound, Visayas Avenue, Vasra, Quezon City 1128 Philippines
T/ (632) 928-8741 to 64 loc. 3301-3319
E-mail: bafs@da.gov.ph
Website: www.bafs.da.gov.ph**