

# **PHILIPPINE NATIONAL STANDARD**

**PNS/BAFS/PAES 229:2017  
ICS 65.060.35**

---

---

## **Design of a Diversion Dam**



### **BUREAU OF AGRICULTURE AND FISHERIES STANDARDS**

BPI Compound Visayas Avenue, Diliman, Quezon City 1101 Philippines  
Phone (632) 920-6131; (632) 455-2856; (632) 467-9039; Telefax (632) 455-2858  
E-mail: [bafpsda@yahoo.com.ph](mailto:bafpsda@yahoo.com.ph)  
Website: [www.bafps.da.gov.ph](http://www.bafps.da.gov.ph)

Design of a Diversion Dam  
PNS/BAFS/PAES 229:2017

Copyright © 2017 by Bureau of Agriculture and Fisheries Standards

All rights reserved. The mention of specific organizations or products, does not mean endorsement or recommendation from the Bureau of Agriculture and Fisheries Standards (BAFS) in preference to other of similar nature that are not included. The BAFS encourages the reproduction and dissemination of the materials upon request. Applications for permissions to reproduce or disseminate these materials and all other queries should be addressed to the publisher.

Published by:

Bureau of Agriculture and Fisheries Standards  
BAFS Building, BPI Compound, Visayas Avenue, Diliman, Quezon City  
info.dabafs@gmail.com | bafs@da.gov.ph  
(+632) 8928 8756 to 65 local 3301 – 3325

ISBN 978-621-455-412-6 (PDF)

[www.bafs.da.gov.ph](http://www.bafs.da.gov.ph)

## **Foreword**

The formulation of this national standard was initiated by the Agricultural Machinery Testing and Evaluation Center (AMTEC) under the project entitled “Enhancement of Nutrient and Water Use Efficiency Through Standardization of Engineering Support Systems for Precision Farming” funded by the Philippine Council for Agriculture, Aquaculture and Forestry and Natural Resources Research and Development - Department of Science and Technology (PCAARRD - DOST).

As provided by the Republic Act 10601 also known as the Agricultural and Fisheries Mechanization Law (AFMech Law of 2013), the Bureau of Agriculture and Fisheries Standards (BAFS) is mandated to develop standard specifications and test procedures for agricultural and fisheries machinery and equipment. Consistent with its standards development process, BAFS has endorsed this standard for the approval of the DA Secretary through the Bureau of Agricultural and Fisheries Engineering (BAFE) and to the Bureau of Philippine Standards (BPS) for appropriate numbering and inclusion to the Philippine National Standard (PNS) repository.

This standard has been technically prepared in accordance with BPS Directives Part 3:2003 – Rules for the Structure and Drafting of International Standards.

The word “shall” is used to indicate mandatory requirements to conform to the standard.

The word “should” is used to indicate that among several possibilities one is recommended as particularly suitable without mentioning or excluding others.

**CONTENTS**

**Page**

<b>1</b>	Scope	1
<b>2</b>	Definitions	1
<b>3</b>	Types of Diversion Dam	1
<b>4</b>	Selection of Diversion Site	3
<b>5</b>	Design Procedure	9
<b>6</b>	Bibliography	26

**ANNEXES**

<b>A</b>	Flood Discharge Analysis	27
<b>B</b>	Determination of Crest Shape	35
<b>C</b>	Structural Stability Analysis	39
<b>D</b>	Sample Computation	43

---

**Design of a Diversion Dam**


---

**1 Scope**

This standard specifies the minimum design requirements of a diversion dam. This type of dam shall be provided across the water source in cases where water is too low to divert water in order to raise its water level to facilitate irrigation by gravity. The height of this type of dam ranges from 3 m to 5 m.

**2 Definition**

For the purpose of this standard, the following definitions shall apply:

**2.1****afflux elevation**

rise in maximum flood level from the original unobstructed flood level which result after an obstruction to the flow such as a dam, has been introduced

**2.2****diversion dam**

structure or weir provided across the river or creek to raise its water level and divert the water into the main canal to facilitate irrigation by gravity.

**2.3****hydraulic jump**

occurs when a thin sheet of incoming flow moving at high velocity strikes water of sufficient depth

**3 Types of Diversion Dams**

The different types of diversion dams and suitability in site conditions are shown in Table 1.

**Table 1. Types of Diversion Dams**

<b>Type</b>	<b>Description</b>	<b>Site Conditions</b>
Ogee	- a weir wherein the upper curve of the ogee is made to conform to the shape of the lower nappe of a ventilated sheet of water falling from a sharp-crested weir - has a high discharge efficiency	- for most sites under normal conditions

Vertical Drop	<ul style="list-style-type: none"> <li>- a weir which produces free-discharging flows and dissipates overflowing water jet with the impact in the downstream apron</li> <li>- not adaptable for high drops on yielding foundation</li> </ul>	<ul style="list-style-type: none"> <li>- for mountain streams with very steep slopes and a hydraulic jump cannot form, the drop height (from the weir crest to the downstream apron) should not exceed 1.50 m and the foundation is firm and unyielding</li> </ul>
Glacis	<ul style="list-style-type: none"> <li>- a weir with a surface that slopes gently downward from the crest to the downstream apron where only the horizontal component of the overflow jet takes part in the impact with the tailwater while the vertical component is unaffected</li> <li>-has stable and predictable hydraulic jump</li> <li>- most adoptable for rivers that have heavy sediment loads</li> </ul>	<ul style="list-style-type: none"> <li>- for weirs not more than 1 m high located on rivers with large, rolling boulders and other debris during flood condition</li> </ul>
Gated	<ul style="list-style-type: none"> <li>- a weir where the larger part of the ponding is accomplished by the solid obstruction or the main body of the weir</li> <li>- additional head can be achieved by installing gates on the crest of the weir which can be collapsed or raised during floods</li> </ul>	<ul style="list-style-type: none"> <li>- for use in rivers or creeks where the afflux level would affect populated or cropped areas on the upstream side of the weir</li> <li>- for sites where the river has heavy sediment loads during floods which could be allowed to pass through the gate openings</li> </ul>
Trapezoidal	<ul style="list-style-type: none"> <li>- weir with sloping upstream and downstream slopes which allow boulders and debris roll over and hit the downstream apron with less impact</li> </ul>	<ul style="list-style-type: none"> <li>- for weirs more than 1 m in height but not exceeding 4 m, located on rivers with large, rolling boulders and other debris during flood condition</li> </ul>
Corewall	<ul style="list-style-type: none"> <li>- used to stabilize the river bed for intake type diversion structures or to gain a limited amount of diversion head</li> <li>- the external part of the weir exposed to water flow is made of pure concrete while the inside part is</li> </ul>	<ul style="list-style-type: none"> <li>- to be used to stabilize the river bed for sites of intake structures requiring only a minimal additional diversion head and where there is a need to maintain a</li> </ul>

	filled with stones and cobbles which provides a more economical section	smooth flow into the intake -the maximum height from the crest to the existing river bed is 0.50 m
--	---	---

ADOPTED FROM: Design of Concrete Gravity Dams on Pervious Foundation

#### **4 Diversion Site Requirements**

**4.1** The site shall have a stable and firm foundation. An impervious foundation is preferred. Otherwise, proper safeguards shall be included in the design.

**4.2** Adequate water supply of good quality shall be available to provide the irrigation needs of the service area. There shall be no potential problems of pollution or saline intrusion.

**4.3** The diversion structure shall be located on a straight river channel reach and shall be located at a certain distance before the next river curvature to avoid scouring of its downstream banks.

**4.4** The site should be selected such that only a short diversion canal will be required. If a long diversion canal is inevitable, there shall be a low diversion dam or weir.

**4.5** The site shall have an adequate waterway width to allow the passage of the maximum design flood without overtopping its banks.

**4.6** A suitable high ground shall be present nearby such that guide banks and protection dikes can be anchored.

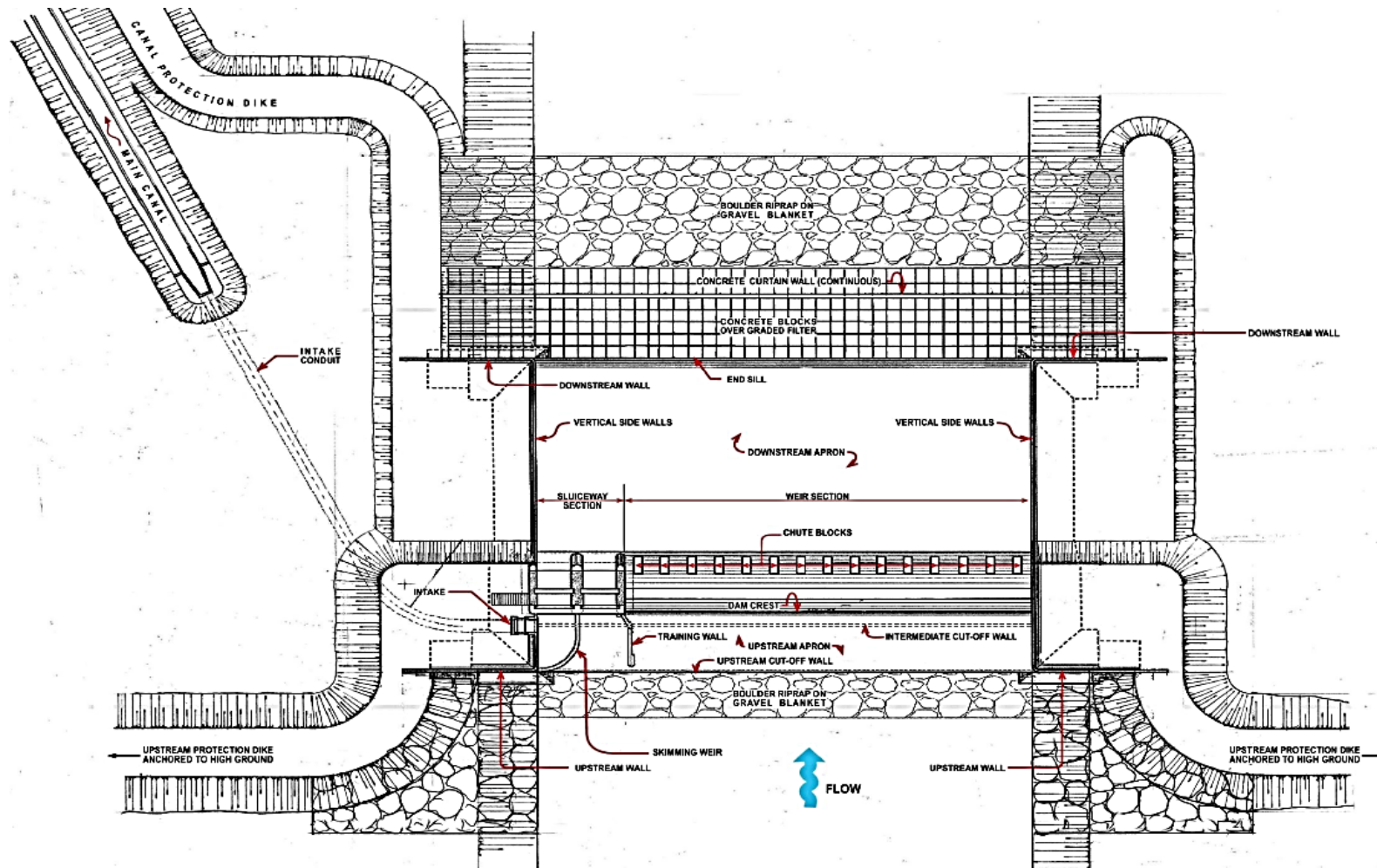
**4.7** Construction materials should be readily available at the site.

**4.8** The site shall be accessible to transportation and with no right-of-way problems.

**4.9** There shall be minimal works required for diversion, coffer damming, dewatering or other special works during construction.

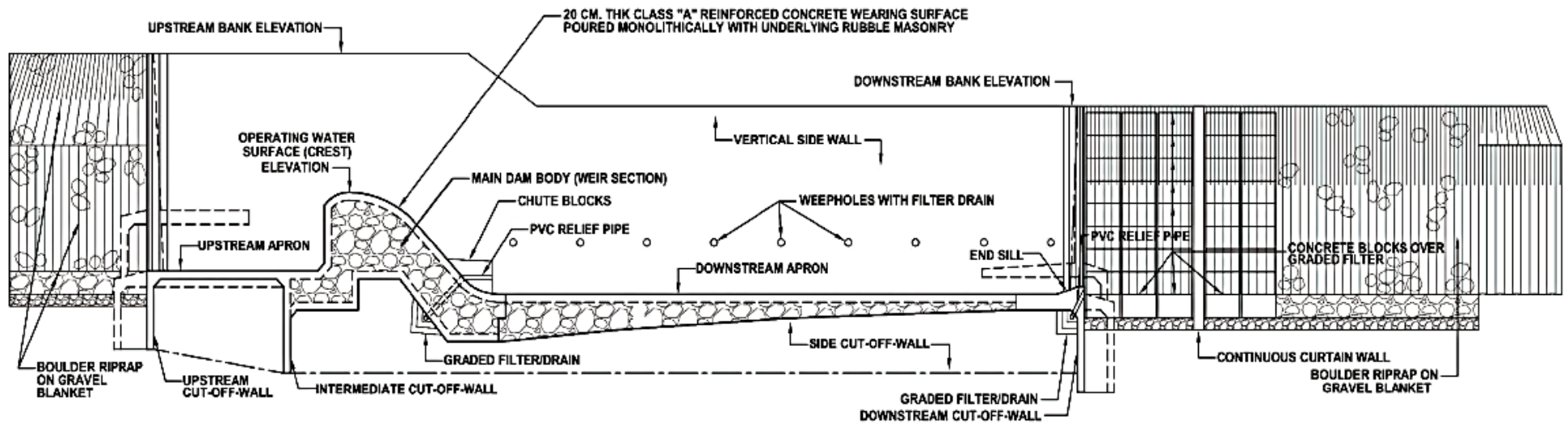
**4.10** There should be no adverse effects on the environment. If inevitable, provisions in the design shall be made to eliminate or mitigate them.

**4.11** Should there be several potential sites for diversion, the most economical site that will provide a hydraulically efficient structure and structurally safe shall be selected.

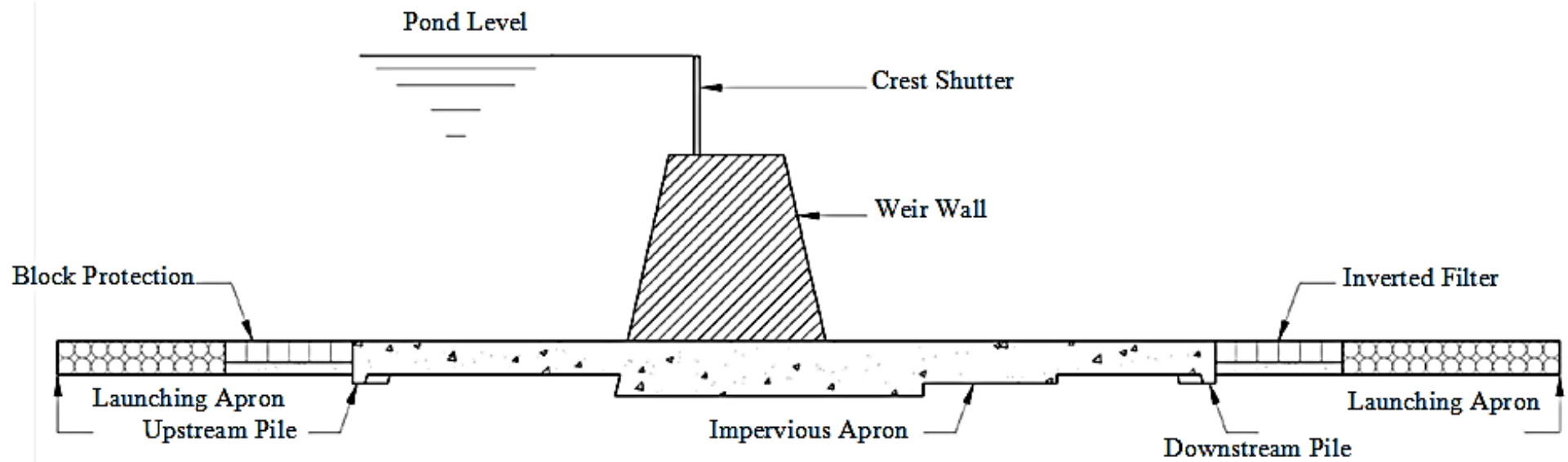


**Figure 1. Plan View of a Diversion Dam Structure**  
 SOURCE: NIA Design Manual for Diversion Dams

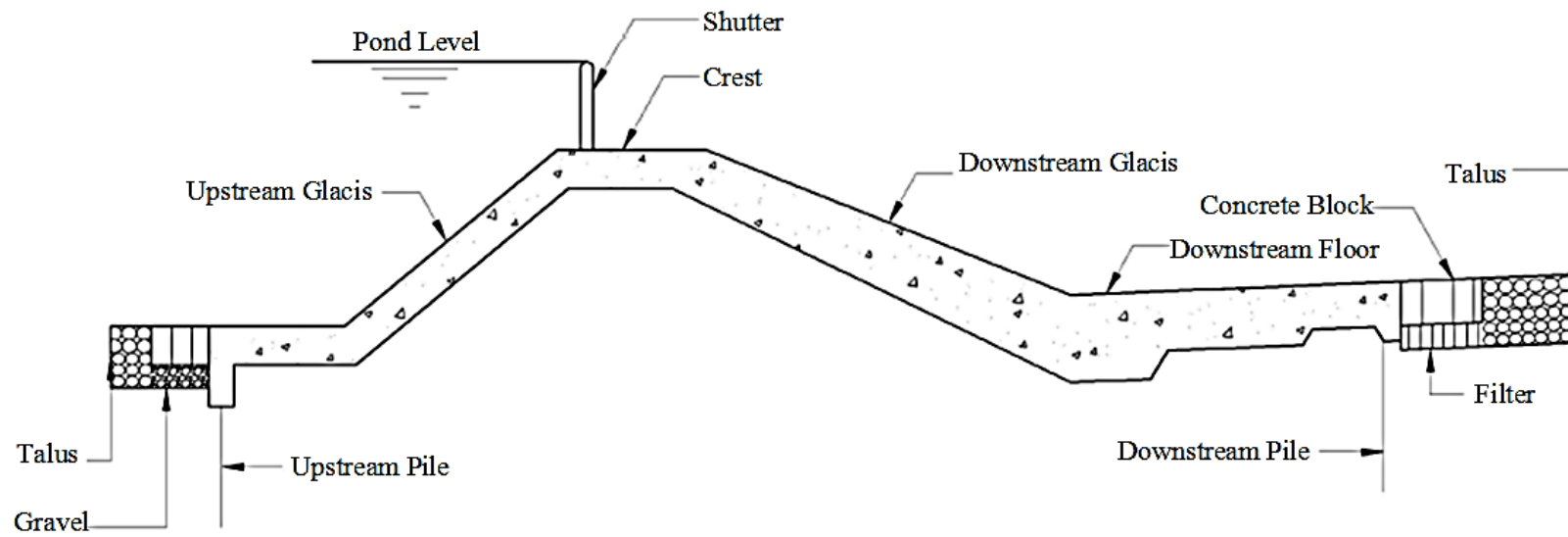




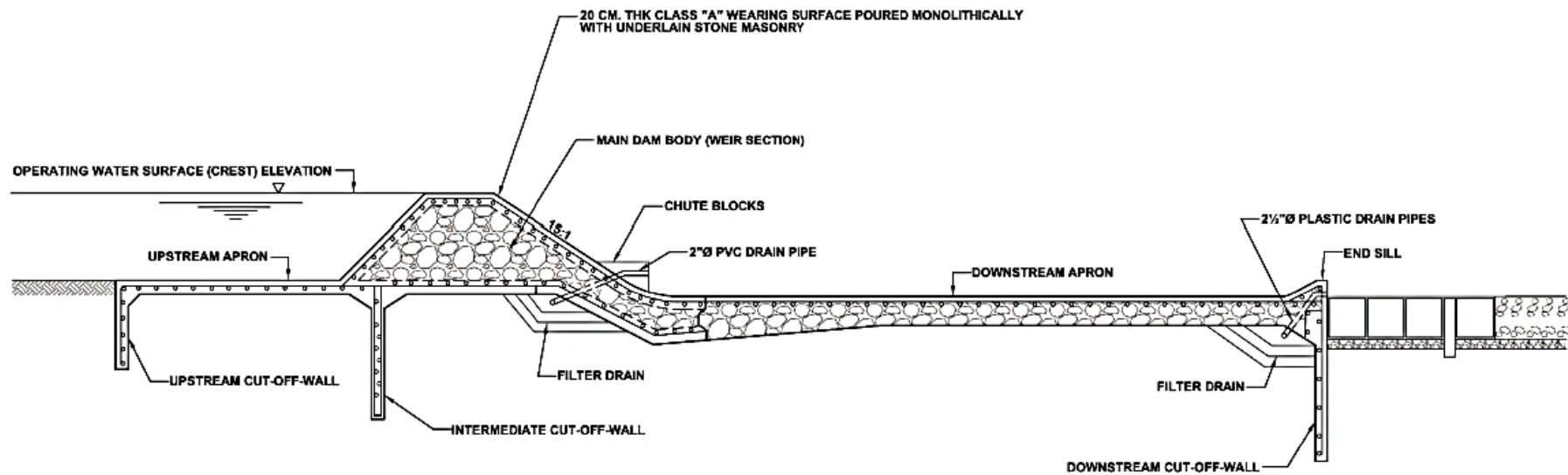
**Figure 2. Section View of an Ogee Diversion Dam Structure**  
 SOURCE: NIA Design Manual for Diversion Dams



**Figure 3. Vertical Drop Diversion Dam Structure**  
 SOURCE: NIA Design Manual for Diversion Dams

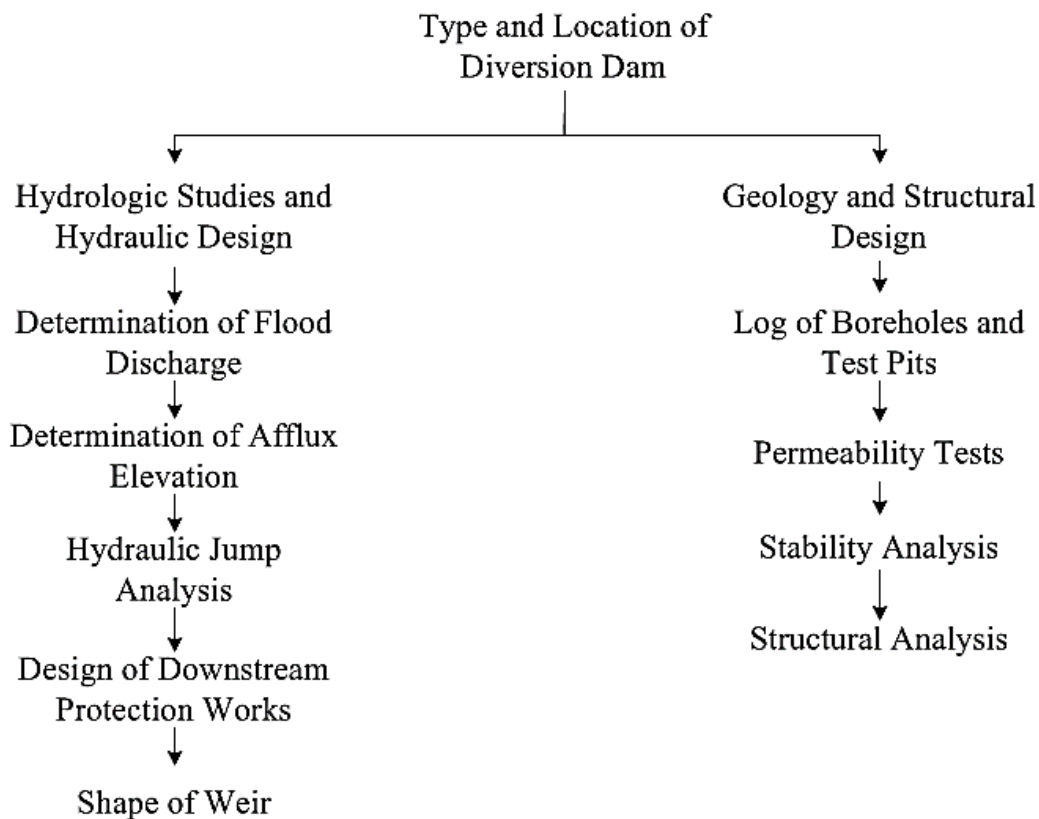


**Figure 4. Glacis Diversion Dam Structure**  
 SOURCE: NIA Design Manual for Diversion Dams



**Figure 5. Trapezoidal Diversion Dam Structure**  
 SOURCE: NIA Design Manual for Diversion Dams

## 5 Design Procedure



**Figure 6. Design Procedure for an Ogee Type Diversion Dam**

### 5.1 Gather required design data.

**5.1.1** Topographic map of the site covering a radius of at least two (2) kilometers, with 1-meter contour interval and a scale of 1:1000 and location of the boreholes

**5.1.2** Rectified aerial photographs of the area.

**5.1.3** Cross-section of the proposed dam axis and at least four (4) cross-sections: two to be taken upstream at points along the river spaced 200 meters apart and the other two at the downstream side of the dam line similarly spaced. Each cross-section shall have the following details:

- Character of the river bed, the nature and kind of vegetation on the banks and flood plains
- Water surface elevation at the time the survey was made
- Maximum flood level elevation as obtained by repeated inquiries from old folks residing in the vicinity
- Ordinary water surface drawn at a scale of 1:100

**5.1.4** Profile of the river bed following the center of the waterway extending at least one kilometer both upstream and downstream of the dam axis with the following details:

- Water surface line at the time of the survey
- Maximum flood line
- Scale of 1:1000 Horizontal and 1:100 Vertical

**5.1.5** Photographs to show the kind of vegetation along the river banks and flood plains for determining the coefficient of roughness

**5.1.6** Boring logs of subsurface explorations shown with the cross-section of the dam axis as well as other logs not taken along the dam axis

**5.1.7** Cores of the borings for further evaluation and interpretation by the designing engineer and also for use as information to bidders

**5.1.8** Stream flow measurements and more comprehensive study of hydrologic data.

**5.2** Determine design flood discharge.

**5.2.1** The following methods may be used if streamflow records are available:

- Slope-Area method
- Gumbel Method and other probability concepts of estimating frequency of occurrence of floods

**5.2.2** The following methods may be used if streamflow records are not available:

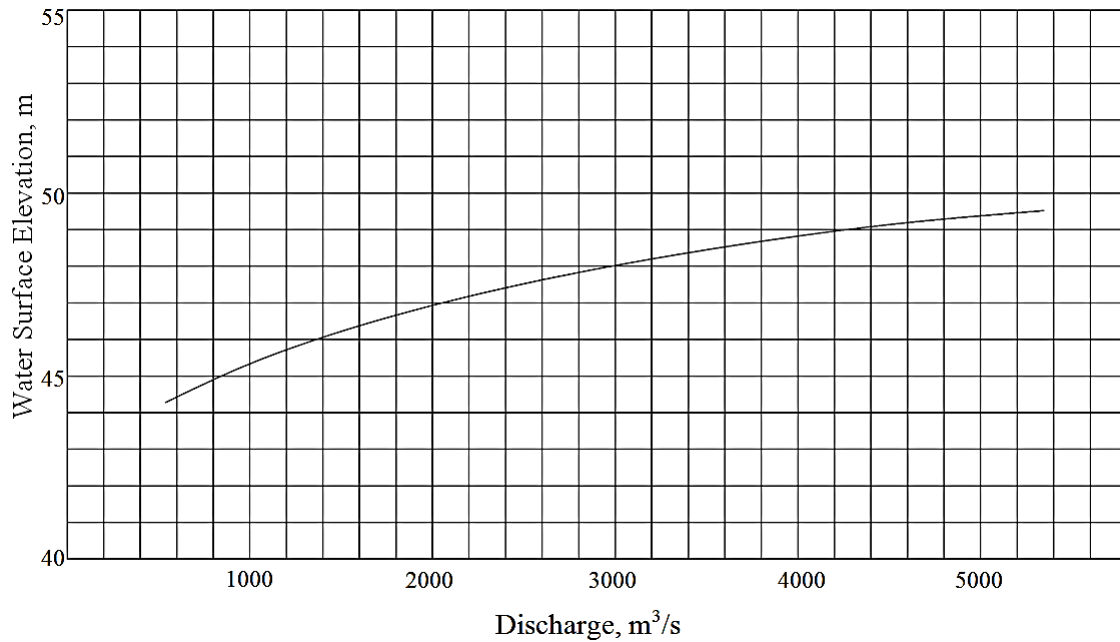
- Correlation Method using Creager's Formula
- Flood Formulas derived from Envelope Curve for the region
- Drainage Area versus Discharge Frequency Curves
- Rational formula
- Modified rational formula

**5.3** Generate a plot of the tailwater rating curve.

**5.3.1** Select the river cross-section 50 meters away from downstream.

**5.3.2** Determine the corresponding discharges at different water levels using the Slope-Area Method discussed in Annex A.

**5.3.3** Plot the values of discharge and elevation on the x- and y-axis, respectively to generate the tailwater rating curve.



**Figure 7. Tailwater Rating Curve**

**5.4** Determine the length of the diversion dam based on the type of foundation material and using the formula below. Table 2 shows the corresponding allowable maximum flood concentration for each type of foundation material.

**Table 2. Allowable Maximum Flood Concentration for Various Foundation Material**

Character of Foundation Material	Allowable Maximum Flood Concentration (m³/s/m)
Fine sand	5
Coarse sand	10
Sand and gravel	15
Sandy clay	20
Clay	25
Rock	50

ADOPTED FROM: Design of Concrete Gravity Dams on Pervious Foundation

$$L_{min} = \frac{Q}{q_{allow}}$$

where:

- $L_{min}$  is the minimum required length of the dam (m)
- $Q$  is the maximum flood discharge (m³/s)
- $q_{allow}$  is the allowable maximum flood concentration (m³/s/m)

**5.4.1** The minimum stable river width shall be checked with the computed minimum dam length. It is preferred to take the average of these values for the length of the dam.

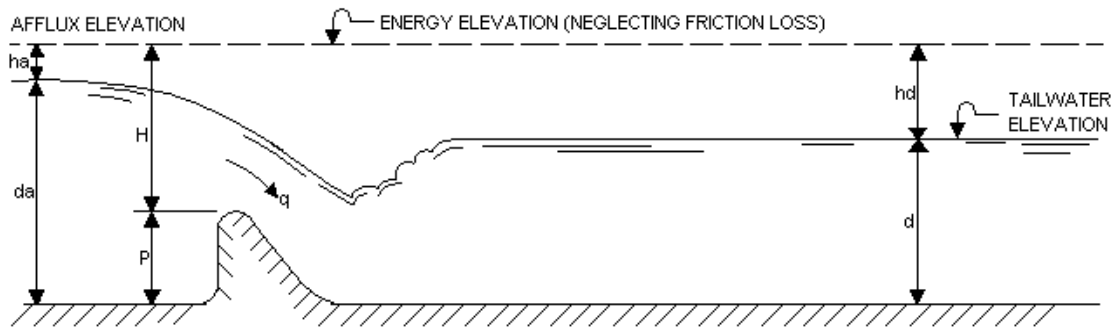
$$P_w = 4.825Q^{1/2}$$

where:

$P_w$  is the minimum required length of the dam, m  
 $Q$  is the maximum flood discharge, m<sup>3</sup>/s

**5.4.2** For upper flood plains, with sandy-loam as the dominant material, the allowable maximum flood concentration shall not be greater than 5 m<sup>3</sup>/s/m with velocity not exceeding 1 m/s to avoid scouring.

**5.5** Determine afflux elevation using a trial-and-error method based on the figure below.



**Figure 8. Afflux Elevation in an Ogee Dam**

SOURCE: Design of Concrete Gravity Dams on Pervious Foundation

**5.5.1** Compute for the unit discharge.

$$q_r = \frac{Q}{L}$$

where:

$q_r$  is the discharge per meter run (m<sup>3</sup>/s/m)  
 $Q$  is the maximum flood discharge (m<sup>3</sup>/s)  
 $L$  is the dam length (m)

**5.5.2** Assume a first trial value of afflux elevation and compute for the following:

$$d_a = EL_{aff} - El_{D/S}$$

$$V_a = \frac{q_r}{d_a}$$

$$h_a = \frac{V_a^2}{2g}$$

where:

$d_a$  is the depth of approach (m)  
 $EL_{aff}$  is the afflux elevation (m)  
 $El_{D/S}$  is the elevation of the downstream floor (m)  
 $V_a$  is the velocity of approach (m<sup>3</sup>/s)



$q_r$  is the discharge per meter run ( $m^3/s/m$ )  
 $h_a$  is the head due to velocity of approach (m)  
 $g$  is the gravitational acceleration ( $m/s^2$ )

**5.5.3** Determine the energy elevation and the head above the dam.

$$EL_{energy} = EL_{aff} + h_a$$

$$H = EL_{energy} - EL_{dam}$$

where:

$EL_{energy}$  is the energy elevation (m)  
 $EL_{dam}$  is the dam elevation (m)  
 $EL_{aff}$  is the afflux elevation (m)  
 $h_a$  is the head due to velocity of approach (m)  
 $H$  is the head above the dam

**5.5.4** Determine the coefficient of discharge for free flow condition,  $C_o$ , using Figure 9.

**5.5.5** Calculate for the coefficient of discharge for flow over submerged dam.

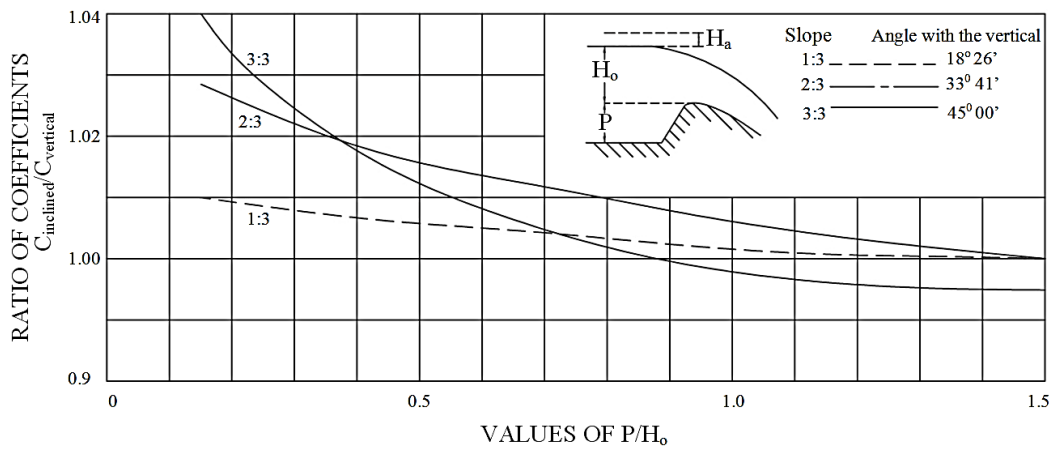
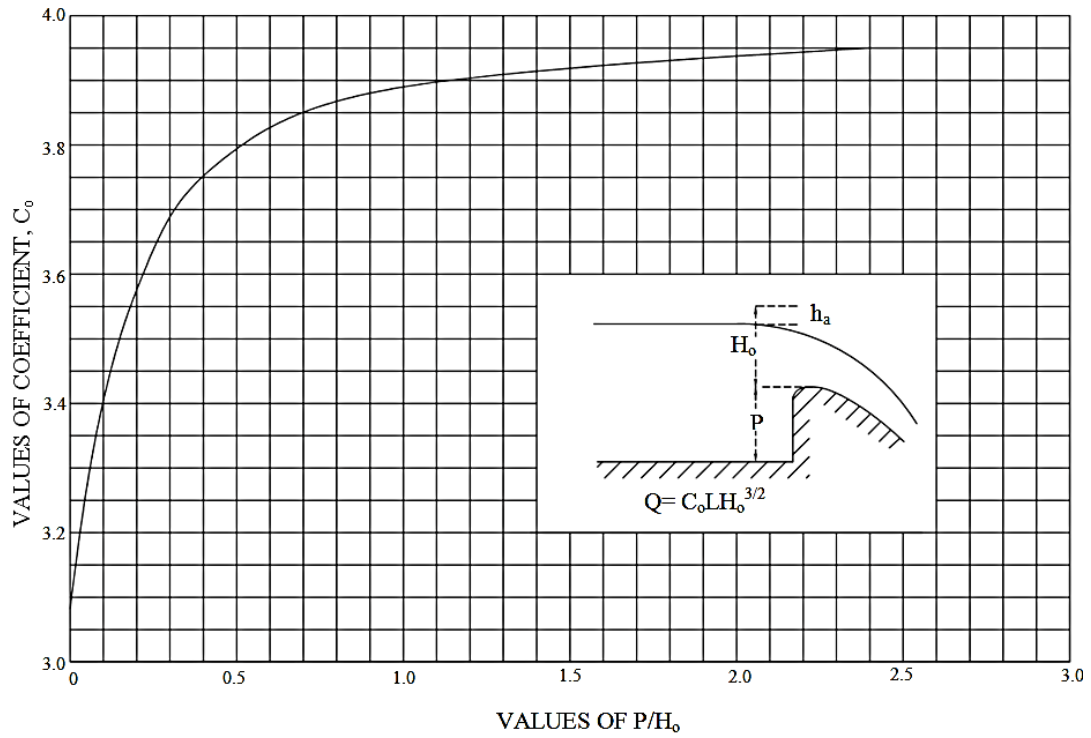
$$C_s = \frac{100 - \% \text{ Decrease}}{100} \times C_o$$

where:

$C_s$  is the coefficient of discharge for flow over submerged dam  
 $C_o$  is the coefficient of discharge for free flow condition  
 $\% \text{ Decrease}$  is the decrease in coefficient of discharge in Figure 10

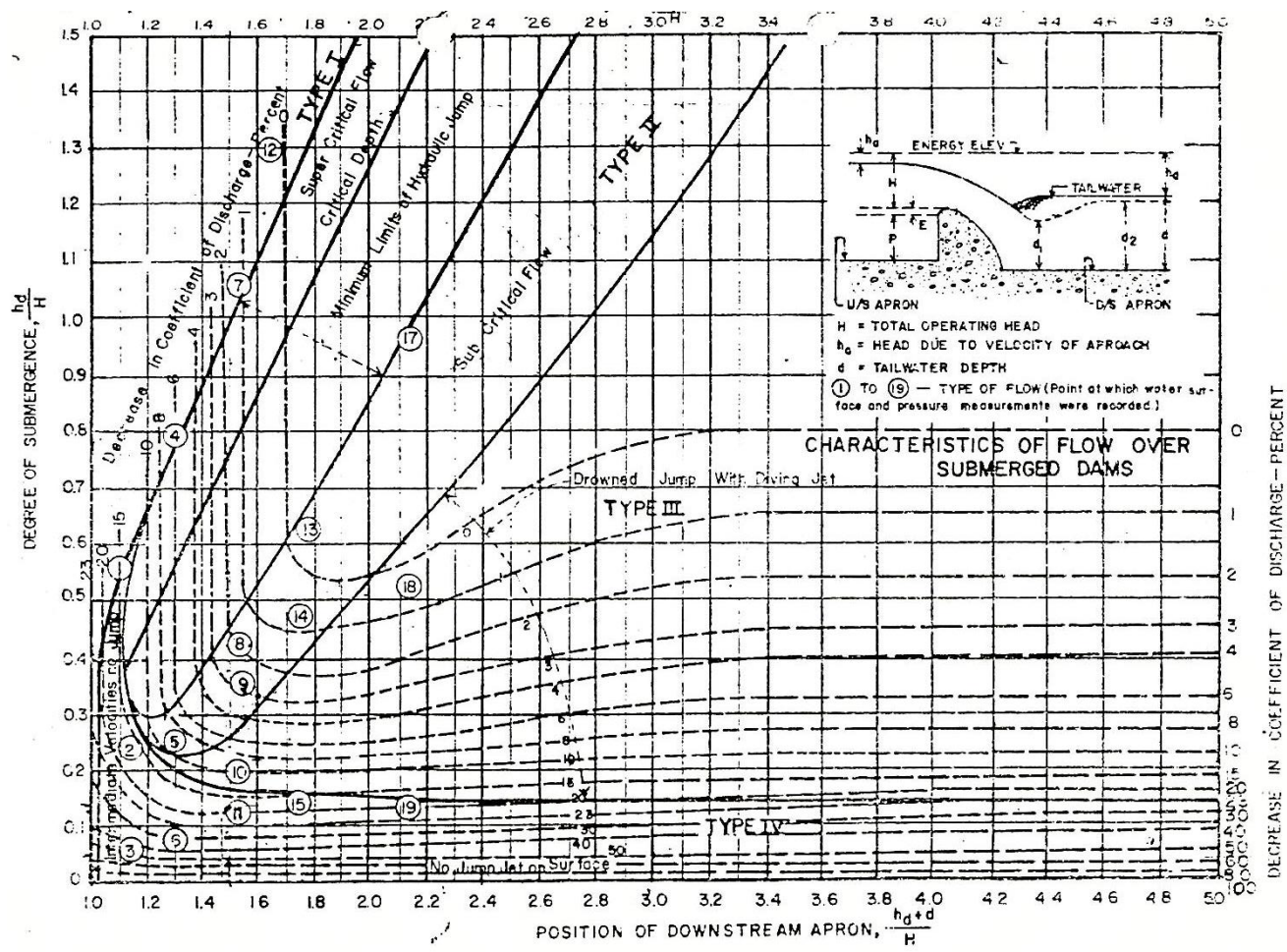
**5.5.6** Solve for the supplied discharge per meter run,  $q_s$ . The obtained value shall be equal to the previously computed  $q_r$ , otherwise, assume another value for the afflux elevation and repeat the procedure above.

$$q_s = \frac{C_s}{1.811} \times H^{3/2}$$



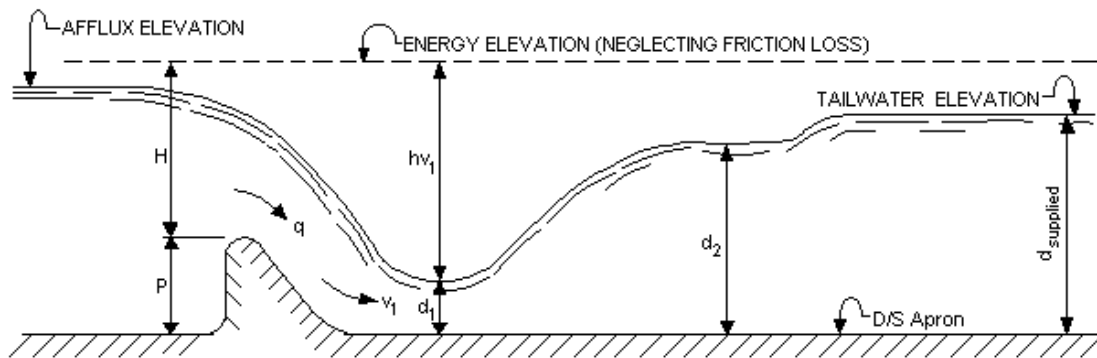
**Figure 9. Coefficient of Discharge for Ogee Crest (a) Vertical-Faced (b) Sloping Upstream Face**

SOURCE: Design of Concrete Gravity Dams on Pervious Foundation



**Figure 10. Characteristics of Flow Over Submerged Dams**  
 SOURCE: Design of Concrete Gravity Dams on Pervious Foundation

5.6 Perform hydraulic jump analysis based on the figure below.



**Figure 11. Hydraulic Jump in an Ogee Dam**

SOURCE: Design of Concrete Gravity Dams on Pervious Foundation

5.6.1 Assume a value of  $d_1$  less than the height of the dam and compute for the head loss due to velocity.

$$V_1 = \frac{q}{d_1}$$

$$h_{v1} = \frac{v_1^2}{2g}$$

where:

- $v_1$  is the velocity of water just upstream before formation of the jump (m)
- $q$  is the discharge per meter run ( $\text{m}^3/\text{s}/\text{m}$ )
- $d_1$  is the assumed depth of water just upstream before formation of the jump (m)
- $h_{v1}$  is the head loss due to velocity (m)
- $g$  is the gravitational acceleration ( $\text{m}/\text{s}^2$ )

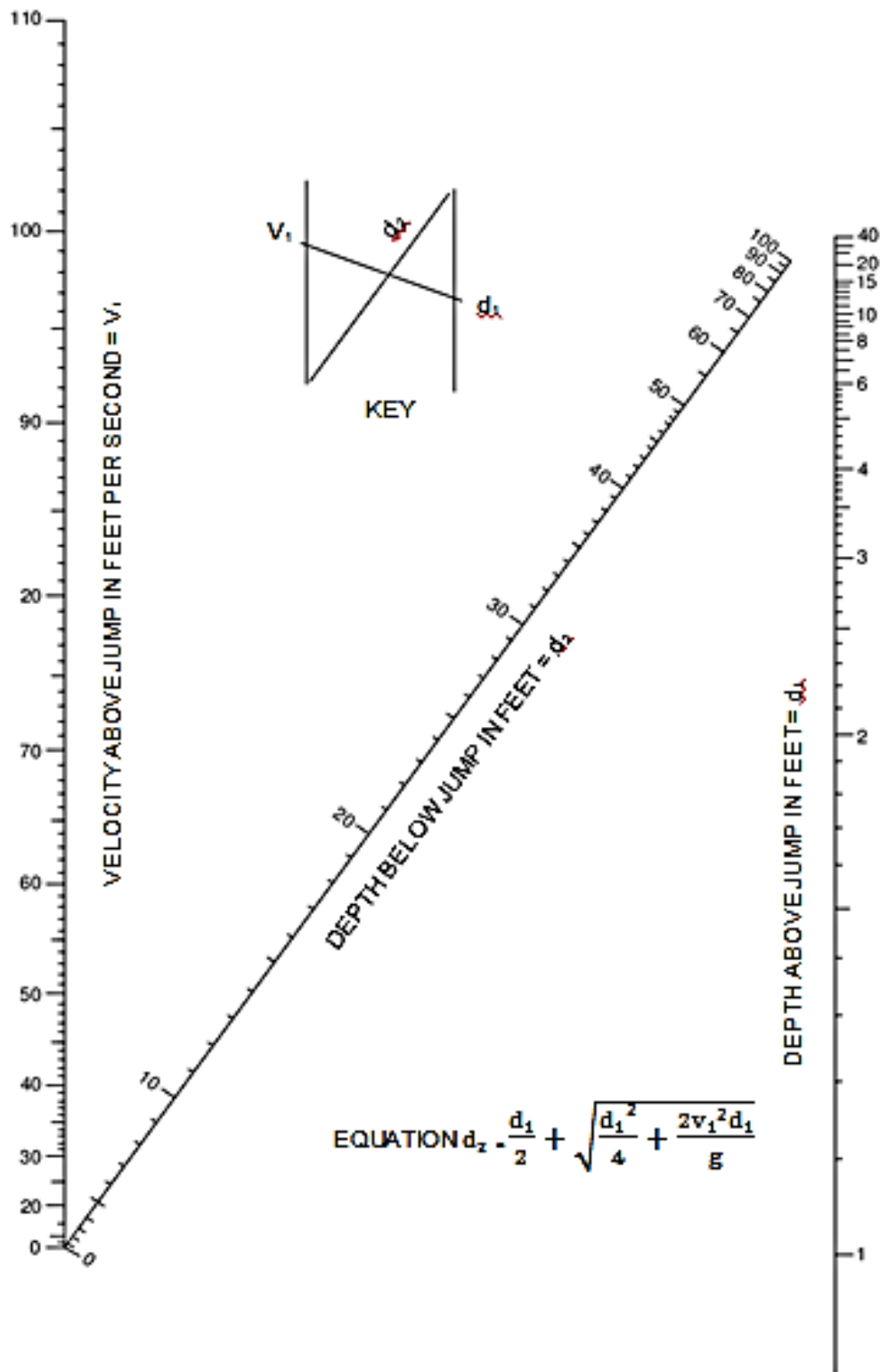
5.6.2 The sum of  $d_1$  and  $h_{v1}$  shall be almost equal to the difference between the energy elevation above the dam and the downstream apron elevation. Otherwise, assume another value for  $d_1$  and repeat the procedure above.

5.6.3 Calculate the jump height,  $d_2$ , or use the nomograph in Figure 12.

$$d_2 = -\frac{d_1}{2} + \sqrt{\frac{d_1^2}{4} + \frac{2v_1^2 d_1}{g}}$$

5.6.4 It must be noted that the position of the hydraulic jump on a horizontal and smooth can hardly be predicted.

5.6.5 The length of the jump should approximately be five times the jump height.



**Figure 12. Nomograph for Hydraulic Jump**  
 SOURCE: Iglesia, Design of Concrete Gravity Dams on Pervious Foundation

**5.7** Compute for the length of downstream apron or follow the recommended length based on the Froude number as shown in Table 3.

$$L_a = 5(d_2 - d_1)$$

where:

- $L_a$  is the length of the downstream apron (m)
- $d_1$  is the depth of water just upstream before formation of the jump (m)
- $d_2$  is the depth of water just downstream of the formation of the jump (m)

$$F = \frac{v^2}{\sqrt{gd}}$$

where:

- $v$  is the water velocity
- $d$  is the hydraulic depth
- $g$  is the gravitational acceleration

**Table 3. Recommended Length of Downstream Apron**

<b>Froude Number</b>	<b>Type of Basin</b>	<b>Formula for Length</b>
< 4.5	Type I basin with dentated end sills	$L_a = 5(d_2 - d_1)$
> 4.5	Type II basin with dentated end sills	$L_a = 3.5 d_2$
> 4.5	Type III basin with dentated end sills	$L_a = 4 d_2$

ADOPTED FROM: Iglesia, Design of Concrete Gravity Dams on Pervious Foundation

**5.8** Determine the size of chute blocks, baffle blocks and end sill using the recommended values in Table 4.

**Table 4. Recommended Sizes of Chute Blocks, Baffle Blocks and End Sill**

<b>Froude Number</b>	<b>Size (cm)</b>		
	<b>Chute Blocks</b>	<b>Baffle Blocks</b>	<b>End Sill</b>
< 2.85	30	60	30
> 2.85	40 to 60	80 to 120	30 to 40

ADOPTED FROM: Iglesia, Design of Concrete Gravity Dams on Pervious Foundation

**5.9** Determine the extent of riprap. The minimum length of riprap shall not be less than 10 meters.

$$L = c \times d_2$$

$$\text{if } F < 4.5, L_{Ra} = 1.5(L - L_a)$$

$$\text{if } F > 4.5, L_{Ra} = (L - L_a)$$

$$v_2 = \frac{q}{d_{supplied}} \times 3.28$$

$$L_{Rb} = \left( \frac{0.65H_o}{d_{supplied}} \right)^{\frac{3}{2}} \times v_2^2$$

$$L_R = \frac{L_{Ra} + \left( \frac{L_{Rb}}{3.28} \right)}{2}$$

where:

L	is the length of natural jump, m
c	is the value from Figure 10
d <sub>2</sub>	is the depth of water just downstream of the formation of the jump, m
L <sub>Ra</sub>	is the first value for the extent of riprap
L <sub>a</sub>	is the length of the downstream apron, m
L <sub>Rb</sub>	is the second value for the extent of riprap, ft
H <sub>o</sub>	is EL <sub>aff</sub> - EL <sub>D/S</sub>
d <sub>supplied</sub>	is the supplied tailwater depth, m
V <sub>2</sub>	is the average tailwater velocity, ft/s
L <sub>R</sub>	is the extent of riprap, m

**5.10** The size of riprap can be determined using two different methods: based on bottom velocity and required stone diameter. For a well-graded riprap, it is recommended to contain about 40% of the size smaller than the required.

**5.10.1** Use Figure 13 for the corresponding size of riprap using the bottom velocity. The bottom velocity shall be computed using the formula below. However, if bottom velocity cannot be determined, the average tailwater velocity is acceptable.

$$v_b = 2.57\sqrt{D}$$

$$v_2 = \frac{q}{d_{supplied}}$$

where:

v <sub>b</sub>	is the bottom velocity (ft/s)
D	is the weighted mean diameter of river bed materials (in)

**5.10.2** Use the required stone diameter for determining the size of riprap.

$$W_R = \frac{4}{3}\pi r^3 \times 165$$

where:

$W_R$  = weight of riprap, lbs  
 $r$  = required stone radius, ft

**5.10.3** The riprap shall be have a thickness 1.5 times greater than the stone diameter.

**5.10.4** The riprap shall be provided with gravel blanket with a thickness half the thickness of the riprap but not less than 12 inches.

**5.11** Determine the depth of downstream cut-off wall.

$$d_{co} = R - d_{supplied}$$

where:

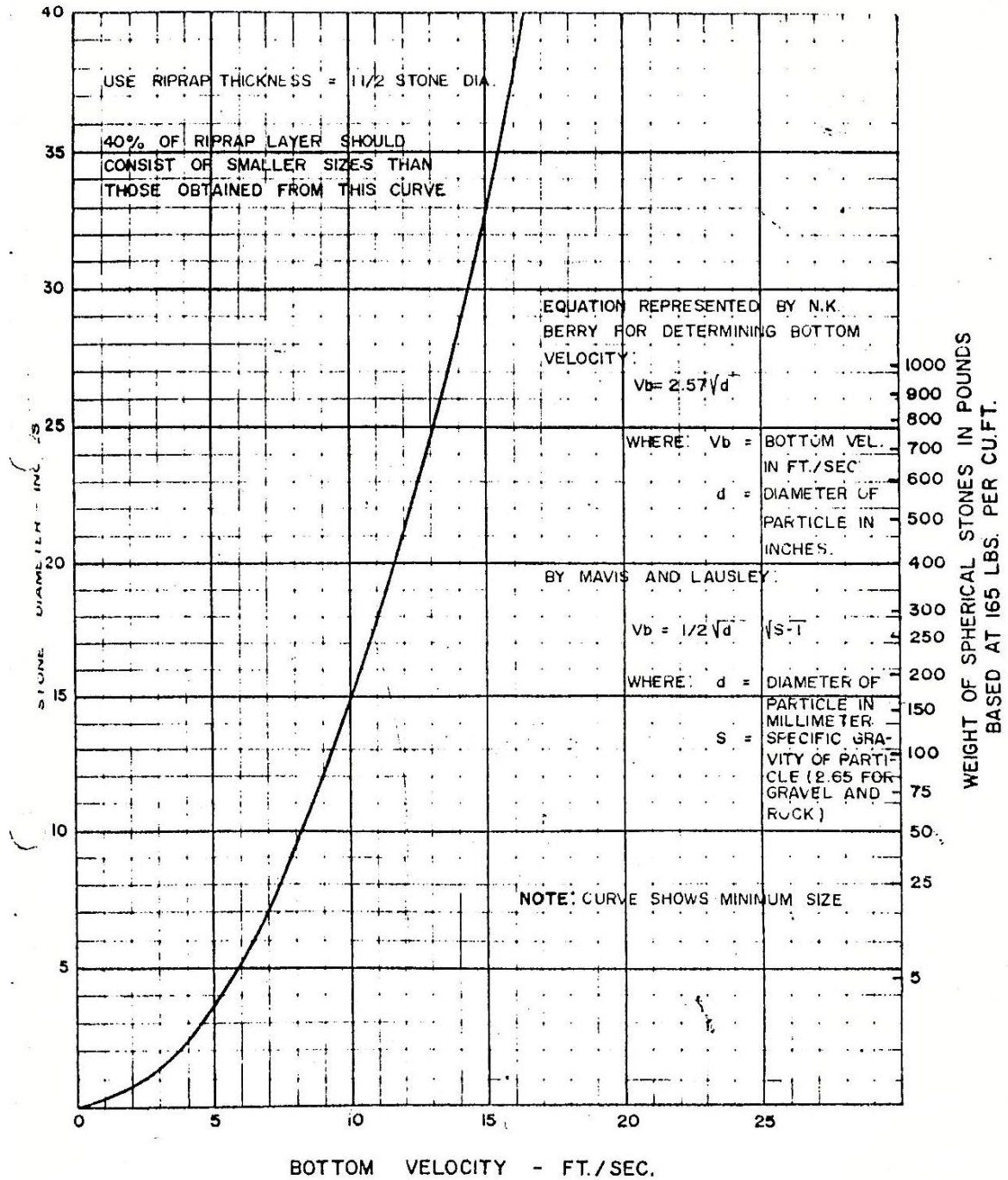
$d_{co}$  = depth of downstream cut-off wall, m  
 $R$  = depth of scour, m (Figure 14)  
 $d_{supplied}$  = depth of tailwater supplied

**5.12** Determine the crest shape detailed in Annex B.

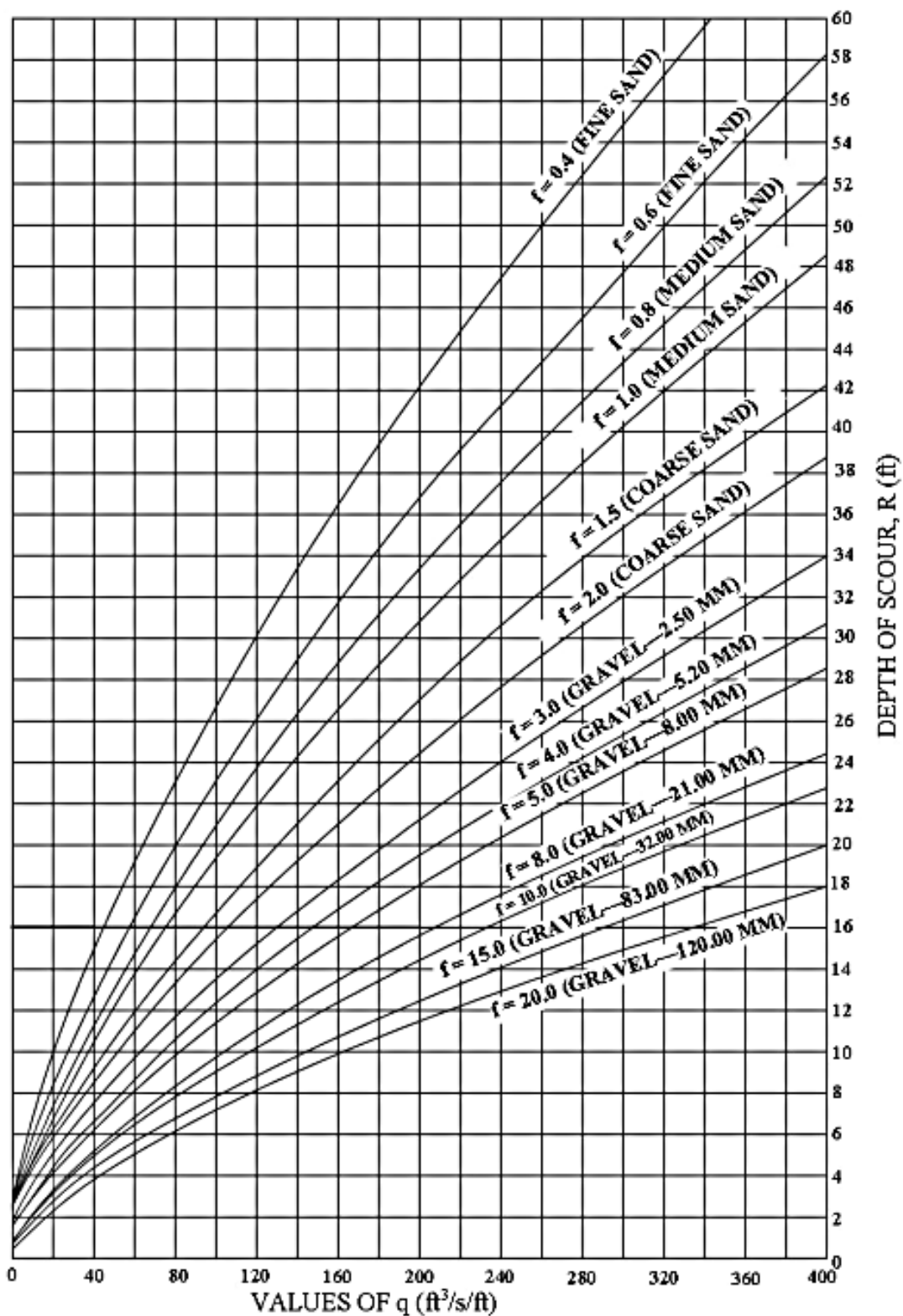
**5.13** Analyze structural stability detailed in Annex C.

**5.14** A sample computation is shown in Annex D.





**Figure 13 . Tentative Curve in Determining Riprap Sizes**  
 SOURCE: United States Bureau of Reclamation, Design of Small Dams, 1967



**Figure 14. Curve for Determining Depth of Scour**

SOURCE: United States Bureau of Reclamation, Design of Small Dams, 1967

## **6 Bibliography**

Chow, V.T. 1959. Open-Channel Hydraulics. New York: McGraw-Hill Book Company, Inc.

Iglesia, G.N. n.d. Design of Concrete Gravity Dams on Pervious Foundation. n.p.

National Irrigation Administration. n.d. Design Manual on Diversion Dams. n.p.

National Resources Conservation Service. 2011. Conservation Practice Standard: Dam Diversion

Stephens, T. 2010. FAO Irrigation and Drainage Paper 64: Manual on Small Earth Dams. Rome: Food and Agriculture Organization of the United Nations

United States Bureau of Reclamation. 1967. Design of Small Dams.

**ANNEX A  
(informative)**

**Determination of Flood Discharge**

**A.1 Slope-Area Method**

**A.1.1** Determine the required parameters:

**Table A1 – List of Required parameters**

Parameter	Symbol	Unit
Slope of the river bed	$S_{rb}$	
Slope of flood water surface	$S_{ws}$	
Water cross-sectional area	A	$m^2$
Wetted perimeter	P	m
Hydraulic radius	R	m
Roughness coefficient	n	
NOTE: If the value of $S_{ws}$ can't be determined, use $S_{rb}$ as "S" in substituting with Manning's Formula		

**A.1.2** Calculate for the average velocity, V (m/s)

$$V = \frac{1}{n} R^{\frac{2}{3}} S^{\frac{1}{2}}$$

**A.1.3** Determine the discharge, Q ( $m^3/s$ )

$$Q = A \times V$$

**Table A2. Roughness coefficient for various channel conditions**

Values of n	Channel Condition
0.020	Smooth natural earth channels, free from growth, little curvature
0.0225	Average, well-constructed, moderate-sized earth channels in good condition
0.025	Small earth channels in good condition, or large earth channels with some growth on banks or scattered cobbles in bed
0.030	Earth channels with considerable growth; natural streams with good alignment; fairly constant section; large floodway channels, well maintained
0.035	Earth channels considerably covered with small growth; cleared but not continuously maintained flood ways
0.040 – 0.050	Mountain streams in clean loose cobbles; rivers with variable section and some vegetation growing in banks; earth channels with thick aquatic growths
0.060 – 0.075	Rivers with fairly straight alignment and cross section, badly

	obstructed by small trees, very little underbrush or aquatic growth
0.100	Rivers with irregular alignment and cross section, moderately obstructed by small trees and underbrush; rivers with fairly regular alignment and cross section, heavily obstructed by small trees and underbrush
0.125	Rivers with irregular alignment and cross section, with growth of virgin timber and occasional dense patches of bushes and small trees, some logs and dead fallen trees
0.150 – 0.200	Rivers with very irregular alignment and cross section, many roots, trees, bushes, large logs, and other drifts on bottom, trees continually falling into channel due to bank caving
0.035	Natural (wide) channel, somewhat irregular side slopes; fairly even, clean and regular bottom; in light gray silty clay to light tan silt loam; very little variation in cross section
0.040	Rock channel, excavated by explosives
0.045	Dredge channel, irregular side slopes and bottom sides covered with small saplings and brush, slight and gradual variations in cross sections
0.080	Dredge (narrow) channel, in block and slippery clay and gray silty clay loam, irregular side slopes and bottom, covered with dense growth of bushes, some in bottom

## A.2 Gumbel Method

A.2.1 For 20-year floods, the graphical linearization approach shall be used.

A.2.1.1 Select the the highest flood discharge, Q, for each year of the 20-year record.

A.2.1.2 Arrange the annual peak discharges in descending order and rank them from 1 to N where N is the number of years of record.

A.2.1.3 Compute for the probability that an event will be exceeded or equalled and the probability that an event will not occur.

$$P = \frac{m}{N + 1}$$

$$P_r = 1 - P$$

where:

P is the probability that the event will be exceeded  
P<sub>r</sub> is the probability that the event will not occur  
m is the rank  
N is the number of records

**A.2.1.4** Plot the values of  $P_r$  and  $Q$  on the x- and y-axis of the Gumbel probability paper, respectively.

**A.2.1.5** Determine the best-fit line through the plotted points.

<b>Q</b>	<b>m</b>	<b>P</b>	<b><math>P_r</math></b>
highest	1		
↓	↓		
lowest	N		

**A.2.2** For 25-year, 50-year and 100-year floods, mathematical approach using statistical principles shall be used.

**A.2.2.1** Determine the standard deviation for the values of the annual peak discharges.

$$D_s = \sqrt{\frac{\sum(Q - \bar{Q})^2}{N - 1}}$$

$$\bar{Q} = \frac{\sum Q}{N}$$

where:

$D_s$  is the standard deviation  
 $\bar{Q}$  is the mean flood discharge  
 $Q$  is the annual peak discharge  
 $N$  is the number of records

**A.2.2.2** Compute for the reduced variate for the required return periods.

$$y = -Ln(Ln \frac{T_r}{T_r - 1})$$

where:

$y$  is the reduced variate  
 $T_r$  is the return period

**A.2.2.3** Compute for the corresponding discharge using the following relation.

$$y = \frac{a'}{D_s} (Q_r - \bar{Q}) + C$$

where:

$y$  is the reduced variate  
 $D_s$  is the standard deviation  
 $Q_r$  is the corresponding discharge  
 $a', C$  is the factors (function of  $N$ )

**Table A3. Values of a' and C**

<b>N</b>	<b>a'</b>	<b>C</b>
10	0.970	0.500
15	1.021	0.513
20	1.063	0.524
25	1.092	0.531
30	1.112	0.536
35	1.129	0.540
40	1.141	0.544
50	1.161	0.549
100	1.206	0.560
1000	1.269	0.574

**A.2.2.4** Plot the values of  $T_r$  and  $Q_r$  on the x- and y-axis of the Gumbel probability paper, respectively.

### **A.3 Runoff Formula**

Determine the flood discharge using the formula below.

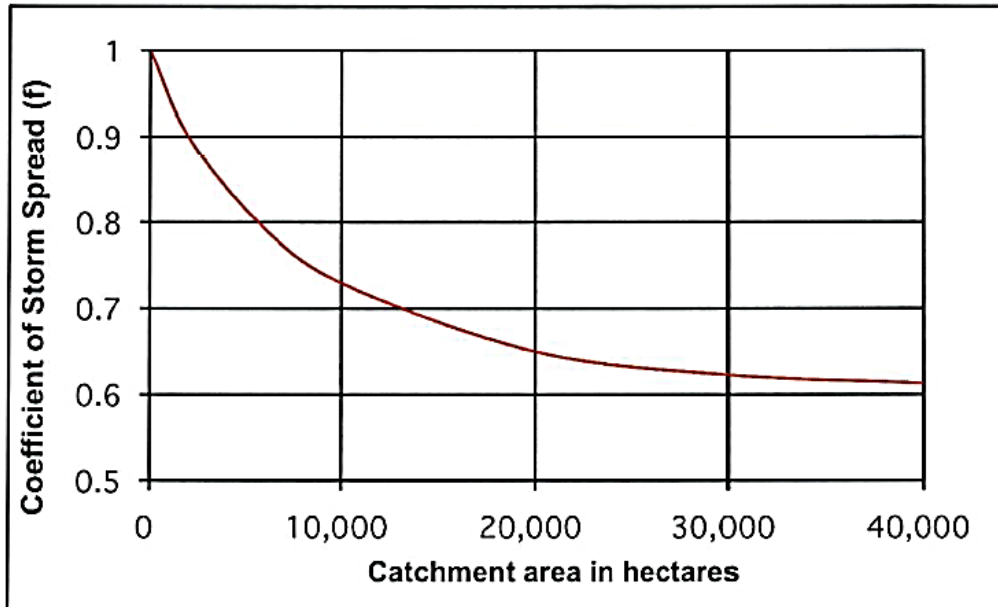
$$Q = 0.028 \times P \times f \times A \times I_c$$

where:

- Q is the flood discharge ( $m^3/s$ )
- P is the percentage coefficient for catchment characteristics (Table A4)
- f is the coefficient for storm spread (Figure A1)
- A is the catchment area (ha)
- $I_c$  is the rainfall intensity (cm/h)

**Table A4 – Percentage coefficient for various catchment characteristics**

<b>Type of Catchment</b>	<b>Maximum Value of P</b>
Steep bare rock	0.90
Rock, steep but wooded	0.80
Plateaus lightly covered	0.70
Clayey soils, stiff and bare	0.60
Clayey soils, lightly covered	0.50
Loam, lightly cultivated or covered	0.40
Loam, largely cultivated	0.30
Sandy soil, light growth	0.20
Sandy soil, covered, heavy brush	0.10



**Figure A1. Coefficient of Storm Spread based on Catchment Area**

#### **A.4 Rational Formula**

Determine the flood discharge using the formula below.

$$Q = F \times C \times I_M \times A$$

where:

- Q is the flood discharge (m<sup>3</sup>/s)
- F is the conversion factor
- C is the runoff coefficient of the catchment (Table A5)
- I<sub>M</sub> is the rainfall intensity (mm/h)
- A is the catchment area (km<sup>2</sup>)

**Table A5. Runoff coefficient for various catchment characteristics**

<b>Type of Catchment</b>	<b>Recommended Values of C</b>
Parks, lawns and gardens	0.05 – 0.25
Open or Unpaved areas	0.20 – 0.30
Light residential areas	0.25 – 0.35
Moderate residential areas	0.30 – 0.55
Dense residential areas	0.50 – 0.75
Suburban areas	0.45 – 0.55
Agricultural lands	0.15 – 0.25
Steep sloped watershed	0.55 – 0.70
Moderately sloped watershed	0.45 – 0.55
NOTE: If the catchment area is of more than one type, use the weighted average value of C.	



## A.5 Modified Rational Formula

Determine the flood discharge using the formula below.

$$Q = K \times C \times I_c \times A$$

where:

Q	is the flood discharge, m <sup>3</sup> /s
K	is the empirical time correction factor to account for decrease of infiltration with time = 0.943T <sub>c</sub> <sup>0.1044</sup> for T <sub>c</sub> < 1.75; T <sub>c</sub> = time of concentration, h = 1.0 for T <sub>c</sub> > 1.75
C	is the runoff coefficient of the catchment (Table A6)
I <sub>c</sub>	is the rainfall intensity, cm/h
A	is the catchment area, km <sup>2</sup>

**Table A6. Runoff coefficient for various catchment characteristics**

Type of Catchment	Recommended Values of C
Low runoff condition (exceptionally well-grassed vegetation, sandy soil, flat topography)	C = 0.0000854 × (100.07) <sup>log<sub>10</sub>I<sub>c</sub></sup> for I <sub>c</sub> < 5 cm/h C = 0.0001465 × (46.54) <sup>log<sub>10</sub>I<sub>c</sub></sup> for I <sub>c</sub> > 5 cm/h
Moderate runoff condition (good vegetation coverage, light soil, gently sloping topography)	C = 0.0006149 × (17.29) <sup>log<sub>10</sub>I<sub>c</sub></sup>
Average runoff condition (good to fair vegetation, medium-textured soil, sloping to hilly topography)	C = 0.002521 × (5.909) <sup>log<sub>10</sub>I<sub>c</sub></sup>
High runoff condition (fair to sparse vegetation, heavy soil, hilly to steep topography)	C = 0.005601 × (3.285) <sup>log<sub>10</sub>I<sub>c</sub></sup>

## A.6 Correlation Method

**A.6.1** Select a similar river within the considered area. There shall be no appreciable difference in the size of the drainage area, watershed characteristic. There shall be hydrologic similarity in terms of rainfall, soil overcomplex, and valley storage and geologic similarity with regard to groundwater flow.

**A.6.2** Perform frequency distribution analysis for the river with streamflow records using Gumbel Method.

**A.6.3** Determine the C factor.

$$C = \frac{Q}{\sqrt{A}}$$

where:

- C is the C factor
- Q is the magnitude of flood in the gaging station (m<sup>3</sup>/s)
- A is the drainage area (km<sup>2</sup>)

**A.6.4** Compute for the magnitude of flood in the river with no streamflow record using the computed C factor.

$$Q_x = C\sqrt{A_x}$$

where:

- C is the C factor
- Q<sub>x</sub> is the magnitude of flood in the river with no streamflow record (m<sup>3</sup>/s)
- A<sub>x</sub> is the drainage area of the river with no streamflow record (km<sup>2</sup>)

## **A.7 Empirical Flood Formula**

**A.7.1** Determine the rare and occasional flows for the river with streamflow records.

$$Q_{rare} = \frac{150A}{\sqrt{A + 17}}$$

$$Q_{occasional} = \frac{85A}{\sqrt{A + 9}}$$

where:

- Q<sub>rare</sub> is the rare flow for the river with streamflow record (m<sup>3</sup>/s)
- Q<sub>occasional</sub> is the occasional flow for the river with streamflow record (m<sup>3</sup>/s)
- A is the drainage area of the river with streamflow record (km<sup>2</sup>)

**A.7.2** Determine the average of these values and use as the flow for the river with no streamflow record.

## **A.8 Drainage Area Vs. Discharge-Frequency Curve**

**A.8.1** Perform frequency analysis using Gumbel Method for the rivers with streamflow records within the same basin.

**A.8.2** Select all 50-year and 100-year flood values and plot on the log-log paper against their corresponding drainage area.

**A.8.3** Determine the best-fit line through the plotted points. This line represents the curve for the basin.

**A.8.4** With the drainage area of the river with no streamflow records, determine the flood value using the curve for the basin.

**ANNEX B**  
**(informative)**

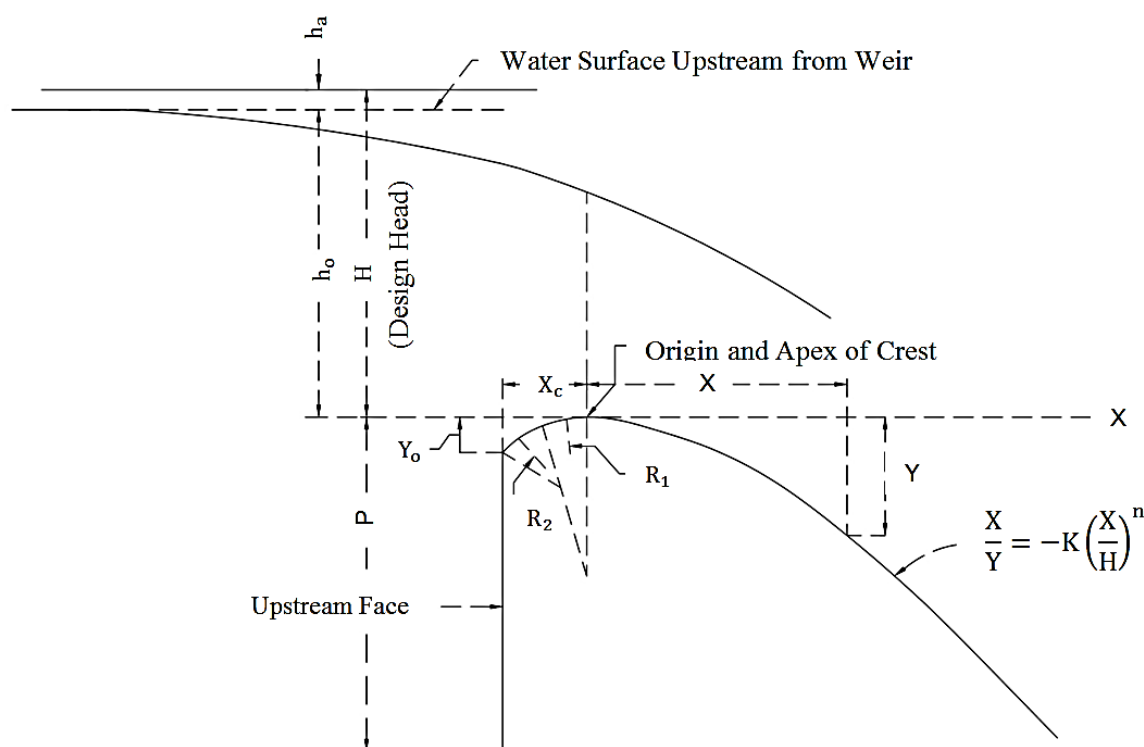
**Determination of Ogee Crest Shape**

The following procedure for the overflow ogee crest is designed to fit the underside of the nappe of a jet flowing over a sharp-crested weir which had been found to be the most ideal for obtaining optimum discharges governed by the equation below. Figure B1 shows the elements of an ogee crest profile.

$$\frac{y}{H} = -K \left( \frac{x}{H} \right)^n$$

where:

- y is the vertical distance from the apex of the crest
- x is the horizontal distance from the apex of the crest
- H is the difference between the energy elevation and dam crest elevation
- K,n is the constants developed based on the upstream inclination and velocity of approach (Figure B3)



**Figure B1. Elements of an ogee crest profile**

**B.1** Using the maximum afflux, energy and dam crest elevations, determine  $h_a/H$ .

**B.2** Determine the location of the apex of the crest ( $X_c$  and  $Y_c$ ),  $R_1$  and  $R_2$  using the computed value of  $h_a/H$  and Figure B2.

**B.3** Determine coefficients  $K$  and  $n$  from Figure B3 and using the formula, complete the plotting table below.

$$y = -KH \left( \frac{x}{H} \right)^n$$

<b>x</b>	<b>x/H</b>	<b>(x/H)<sup>n</sup></b>	<b>y</b>

**B.4** Plot the values to determine the crest shape as shown in Figure B4.

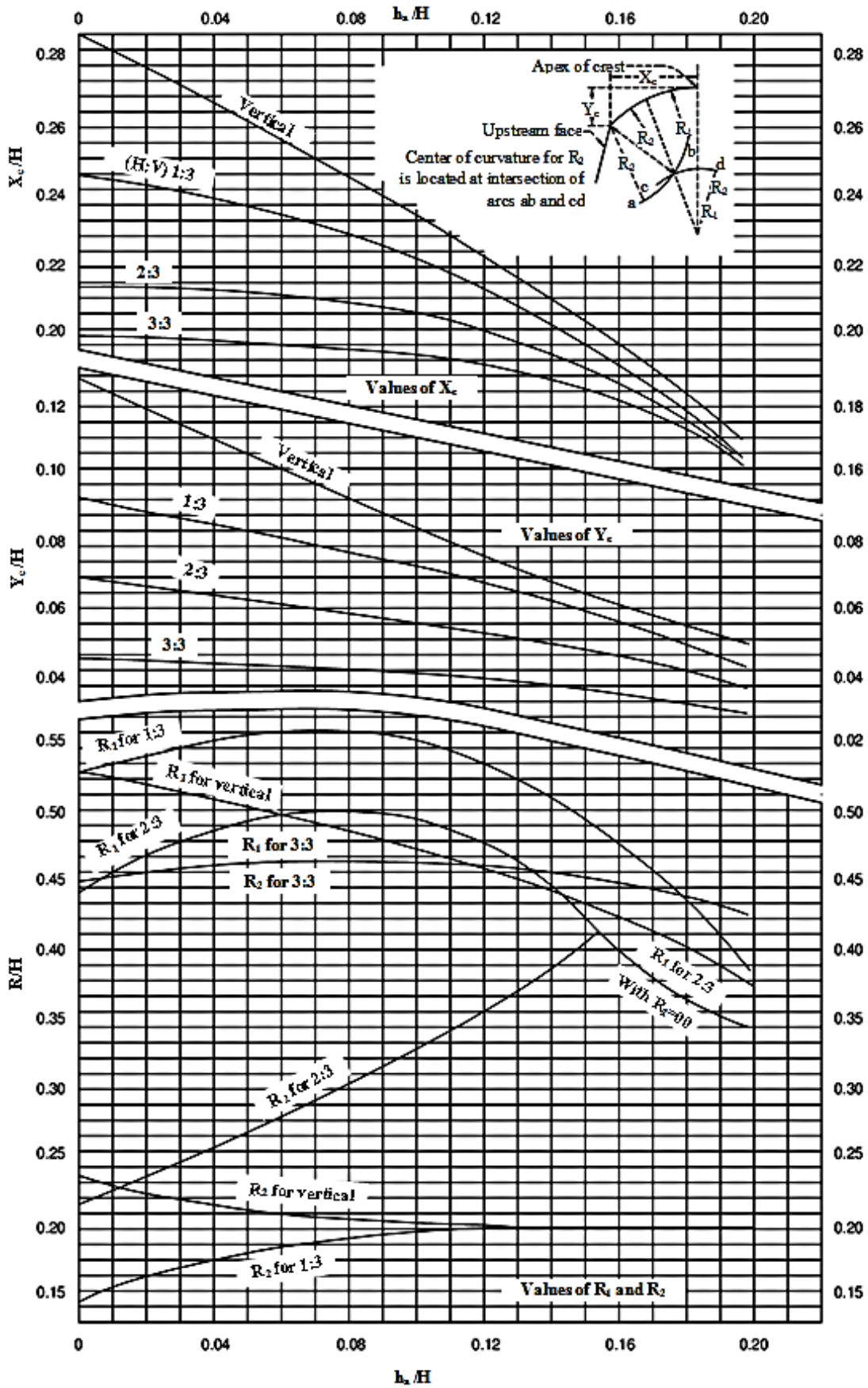


Figure B2. Values of  $X_c$  and  $Y_c$

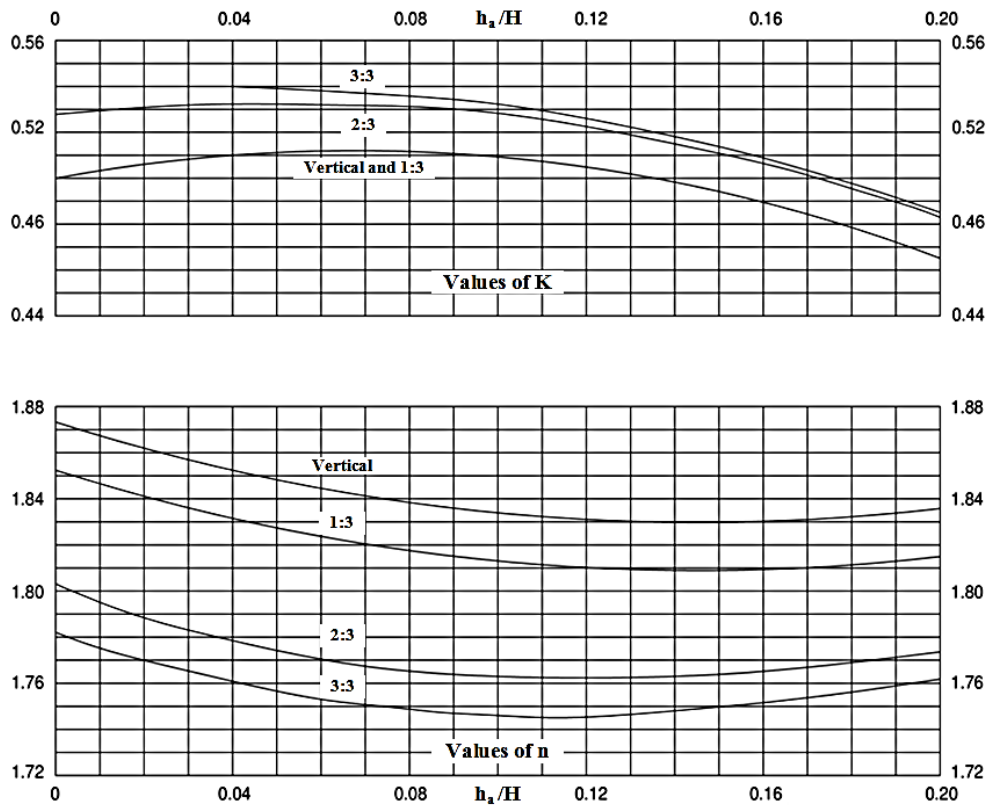


Figure B3. Values of K and n coefficients

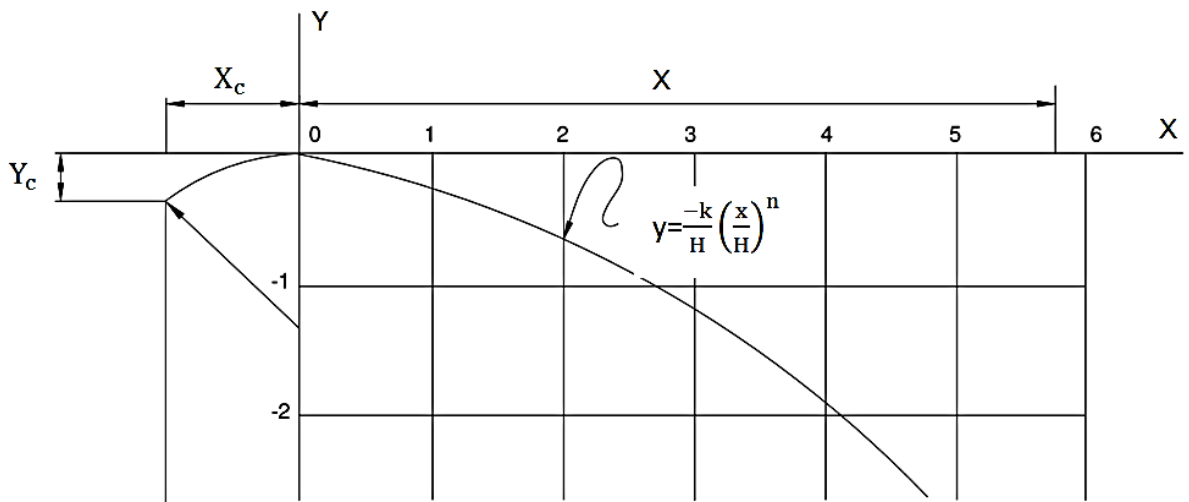


Figure B4. Plotting for the crest shape

**ANNEX C  
(informative)**

**Structural Stability Analysis**

**C.1** The following are the basic assumptions in structural stability analysis:

**C.1.1** The bearing power of the foundation can sustain the total loads from the dam and other external.

**C.1.2** The base of the dam is properly installed on undisturbed foundation.

**C.1.3** There is homogeneity of concrete in all parts of the structure.

**C.1.4** The dam may be considered as a single structure as long as the construction joints are adequately provided with open slots or shear keys and properly filled with concrete.

**C.1.5** Uplift pressure under the dam is reduced by sufficient filter drains and properly installed weep holes.

**C.1.6** In the event of temporary abnormal loads, such as those produced by earthquake shocks, adjustments in the allowable stresses and factors of safety are permissible.

**C.1.7** A cross-section of unit width under analysis is assumed independent of adjoining sections and the beam action in the dam as a whole is disregarded.

**C.1.8** The resistance offered by steel sheet piles or cut-offs against sliding and overturning is disregarded.

**C.2** The following factors of safety shall be considered:

**C.2.1** Under normal stable condition, the factor of safety against overturning ranges from 1.5 to 2 and can be reduced to 1 considering seismic forces.

**C.2.2** If the ratio of the summation of all horizontal forces to the summation of all vertical forces is equal to or less than the allowable sliding factor,  $f$ , the dam is considered safe. Table C.1 shows the allowable sliding factor for various foundation materials.

**Table C.1. Allowable sliding factor for various foundation materials**

Foundation Material	Sliding Factor, $f$
Sound rock, clean and irregular surface	0.8
Rock, some jointing and laminations	0.7
Gravel and coarse sand	0.4
Sand	0.3



Shale	0.3
Silt and clay	Laboratory test necessary

**C.2.3** A concrete cut-off designed as a cantilever beam loaded with the horizontal force that is in excess of the foundation's resistance to sliding, will prevent dam displacement.

**C.3** The following are the conditions with which stability analysis should be made. In all conditions, the resultant shall be located the middle third of the base of the dam and the allowable bearing capacity of foundation materials shall be less than the allowable value as shown in Table C.1.

- During maximum flood condition
- During normal operation condition when the water surface is at the same level as the dam crest and tailwater is at the same level as the downstream apron
- During construction

**Table C1. Suggested Allowable Bearing Values for Footings of Structures Appurtenant to Small Dams**

<b>Material</b>	<b>Condition, Relative Density or Consistency</b>	<b>Average Standard Penetration Values (Number of Blows/Feet)</b>	<b>Allowable Bearing Pressure (tons/ft<sup>2</sup>)</b>
Massive igneous metamorphic or sedimentary rock like granite, gneiss and dolomite	Sound (minor cracks allowed)	-	100
Hard laminated rock including bedded limestone, schist and slate	-	-	35
Sedimentary rock including hard shales, sandstones and thoroughly cemented conglomerates	Shattered or broken	-	10
Gravel (GW, GP, GM, GC)	-	-	4
Cohesionless sands (SW, SP)	Loose	4 to 8	Requires compaction
	Medium	8 to 40	Requires compaction
	Dense	8 to 40	1
Saturated cohesive	Soft	4	0.25

sands, silts and clays (SM, SC, ML, CL, MH, CH)	Medium Stiff Hard	4 to 10 11 to 20 20	0.50 1.0 1.5
<p>NOTE: Unsound shale is treated as clay.</p> <p>GW denotes group symbol for well-graded gravels, gravel-sand mixtures with little or no fines</p> <p>GP denotes group symbol for poorly graded gravels, gravel sand mixtures with little or no fine</p> <p>GM denotes group symbol for silty gravels, poorly graded gravel-sand-silt mixtures.</p> <p>GC denotes group symbol for clayey gravels, poorly graded gravels, poorly graded gravel-sand-clay mixtures.</p> <p>SW denotes group symbol for well-graded sands, gravelly sands with little or no fines.</p> <p>SP denotes group symbol for poorly graded sands, gravelly sands with little or no fines.</p> <p>SM denotes group symbol for silty sands, poorly graded –silt mixtures.</p> <p>SC denotes group symbol for clayey sands, poorly graded sand-clay mixtures.</p> <p>ML denotes group symbol for inorganic silts and very fine sands, rock flour silty or clayey fine silts with slight plasticity.</p> <p>CL denotes group symbol for inorganic clays of low to medium plasticity, gravelly clays, sandy clays, silty clays lean clays</p> <p>MH denotes group symbol for inorganic silts micaceous or diatomaceous fine sandy or silty soils, elastic silts.</p> <p>CH denotes group symbol for inorganic clays o high plasticity, fat clays.</p>			

REFERENCE: United States Bureau of Reclamation. 1967. Design of small dams.

**C.4** The following forces shall be taken into consideration during stability analysis:

- Water pressure (external and uplift)
- Silt pressure
- Earthquake
- Weight of the structure
- Resulting reaction of the foundation

**C.4.1** Water Pressure

**C.4.1.1** Determine the external forces in the dam using Figures C.1 and C.2.

**C.4.1.2** Determine uplift pressures using either of the accepted methods:

- Bligh’s Line-of-Creep Theory
- Lane’s Weighted- Creep Ratio Principle
- Flow Net Analysis
- Khosla’s Method

**C.4.1.3** The procedures described below is based on Lane's Weighted- Creep Ratio Principle. Other established methods preferred by the designer may be used.

**C.4.1.3.1** Verify that there is no short path condition such that the distance between the bottom of two successive cutoffs is greater than or equal to half of the weighted creep distance between them.

**C.4.1.3.2** Determine if the foundation material is safe.

**C.4.1.3.3** Determine the uplift head under the assumption that the drop in pressure head from headwater to tailwater along the contact line of the dam and the foundation is proportioned to the weighted-creep distance.

**C.4.2** Silt Pressure – It may be assumed that a horizontal pressure due to silt load is equivalent to 85 lbs/ft<sup>3</sup> fluid pressure and vertical weight of 120 lb/ft<sup>3</sup>.

**C.4.3** Earthquake Forces

**C.4.3.1** The effect of earthquake forces on the gravity dam itself is determined by applying 0.15g for horizontal acceleration to the energy formula at the center of gravity of the dam.

**C.4.3.2** The effect of horizontal earthquake on water pressure is determined by the hydrodynamic pressure using Figures C3 and C4.

**C.4.4** Weight of the structure – It includes the weight of the concrete and appurtenance structure where the unit weight of concrete is estimated at 150 lbs/ft<sup>3</sup> and the sectional weights act vertically through the center of gravity of each subsection.

**C.4.5** Reaction of the Foundation – Determine the foundation reaction at the toe and heel of the dam similar to analysing the stability of retaining walls.

**ANNEX D  
(informative)**

**Sample Computation**

**D.1 Design Data**

Drainage Area	A	780 km <sup>2</sup>
Drainage Area at Gaging Station	A <sub>g</sub>	900 km <sup>2</sup>
Return Period		100 years
Maximum Allowable Flood Concentration	q	15 m <sup>3</sup> /s/m
Afflux Elevation	EL <sub>aff</sub>	
Upstream Elevation	EL <sub>U/S</sub>	
Downstream Elevation	EL <sub>D/S</sub>	
Tailwater Elevation	EL <sub>TW</sub>	
Tailwater depth	d <sub>TW</sub>	7.50 m
Energy Elevation	EL <sub>energy</sub>	
Dam Crest Elevation	EL <sub>dam crest</sub>	
Dam Crest Height	P	3.00 m
Free Flow Coefficient	C <sub>o</sub>	From Figure

**D.2 Determination of the Design Flood Discharge**

**D.2.1 Using Empirical Formula**

(A.A. Villanueva and A.B. Deleña's Flood Formulas for Central Luzon)

$$Q_{\text{rare}} = \frac{150A}{\sqrt{A + 13}} = \frac{150 \times 780}{\sqrt{780 + 13}} = 4170 \text{ m}^3/\text{s}$$

$$Q_{\text{occ}} = \frac{85A}{\sqrt{A + 9}} = \frac{85 \times 780}{\sqrt{780 + 9}} = 2370 \text{ m}^3/\text{s}$$

**D.2.2 Using Drainage-Area-Discharge-Frequency Curve**

Using Figure A-2

$$Q = 3700 \text{ m}^3/\text{s}$$

**D.2.3 Using Correlation Method**

**D.2.3.1 Acquire recorded annual peak flow at gaging station**

Year	Flow Rate (m <sup>3</sup> /s)	Year	Flow Rate (m <sup>3</sup> /s)
1951	2000	1959	950
1952	2500	1960	800
1953	1900	1961	1200

1954	2300	1962	3000
1955	1500	1963	1000
1956	1100	1964	850
1957	1300	1965	900
1958	1800		

**D.2.3.2** Perform frequency distribution analysis by Gumbel Method

Magnitude (in descending order)	$Q - \bar{Q}$	$(Q - \bar{Q})^2$
3000	1460	2132600
2500	960	921600
2300	760	577600
2000	460	211600
1900	360	129600
1800	260	67600
1500	-40	1600
1300	-240	57600
1200	-340	115600
1100	-440	193600
1000	-540	291600
950	-590	348100
900	-640	409600
850	-690	476100
800	-740	547600
$\Sigma = 23100$		$\Sigma = 6482000$

$$\bar{Q} = \frac{23100}{15} = 1540 \text{ m}^3/\text{s}$$

**D.2.3.2.1** Determine the standard deviation.

$$D_s = \sqrt{\frac{\Sigma(Q - \bar{Q})^2}{N - 1}} = \sqrt{\frac{6482000}{14}} = 680$$

**D.2.3.2.2** Determine the reduced variate.

$$y = -\ln\left(\ln\frac{T_r}{T_r - 1}\right) = -2.3 \log\left(2.3 \log\frac{100}{99}\right) = 4.61$$

**D.2.3.2.3** Using the other equation for reduced variate and values of  $a'$  and  $C$  from Table, determine the discharge at  $T = 100$  for the gaging station.

$$y = \frac{a'}{D_s}(Q_r - \bar{Q}) + C = \frac{1.021}{680}(Q_{100} - 1540) + 0.513$$

$$Q_{100} = 4300 \text{ m}^3/\text{s}$$

**D.2.3.2.4** Using Creager's Formula,

$$C = \frac{Q_{100}}{\sqrt{A}} = \frac{9300}{\sqrt{900}} = 143$$

**D.2.3.2.5** Apply the above C-factor to the proposed damsite to determine discharge.

$$Q_{100} = C\sqrt{A} = 143\sqrt{780} = 4000 \text{ m}^3/\text{s}$$

Method	Discharge (m <sup>3</sup> /s)
Empirical Formula	3270
Drainage Discharge-Frequency Curve	3700
Correlation Method	4000
Average	3656.67
<b>Design Flood Discharge = 3700 m<sup>3</sup>/s</b>	

### **D.3 Determine and Plot the Tailwater Rating Curve**

### **D.4 Determination of the Length of Diversion Dam**

**D.4.1** Determine the allowable maximum flood concentration,  $q_{\text{allow}}$  from Table 2.

**D.4.2** Calculate minimum required length,  $L_{\text{min}}$ .

**D.4.2.1** Using the formula,

$$L = \frac{Q}{q_{\text{allow}}} = \frac{3700 \text{ m}^3/\text{s}}{15 \text{ m}^3/\text{s}/\text{m}} = 247 \text{ m}$$

**D.4.2.2** Using Lacey's formula,

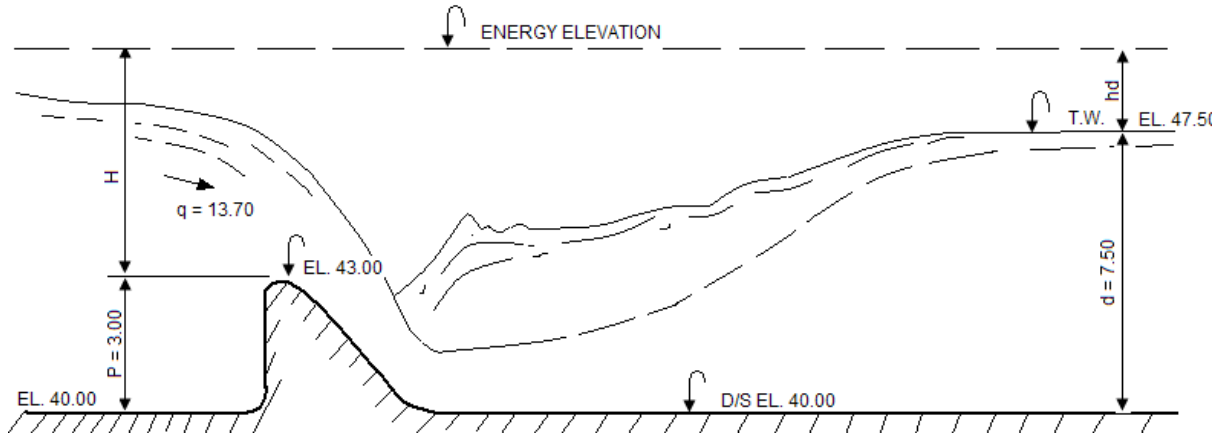
$$P_w = 2.67Q^{1/2} = 2.67 \times (13000 \text{ ft}^3/\text{s})^{1/2} = 965 \text{ ft or } 294 \text{ m}$$

**D.4.2.3** Take the average as the minimum required length.

$$L_{\text{min}} = \frac{L + P_w}{2} = \frac{247 \text{ m} + 294 \text{ m}}{2} = 270.50 \text{ m or } 270.00 \text{ m}$$

### **D.5 Determination of Afflux Elevation**

**D.5.1** Set the required dam crest level and tailwater depth reckoned from the upstream apron as illustrated below.



**D.5.2** Compute for  $q$  using trial and error method until  $q = q_r$ .

$$q_r = \frac{Q}{L_{\min}} = \frac{3700 \text{ m}^3/\text{s}}{270 \text{ m}} = 13.70 \text{ m}^3/\text{s}/\text{m}$$

**D.5.2.1** At afflux elevation of 48.10 m,

$$d_a = EL_{\text{aff}} - EL_{D/S} = 48.10 \text{ m} - 40.00 \text{ m} = 8.10 \text{ m}$$

$$V_a = \frac{q_r}{d_a} = \frac{13.70 \text{ m}^2/\text{s}}{8.10} = 1.70 \text{ m/s}$$

$$h_a = \frac{V_a}{2g} = \frac{(1.70)^2}{19.6} = 0.148 \text{ m}$$

$$EL_{\text{energy}} = EL_{\text{aff}} + h_a = 48.10 \text{ m} + 0.148 \text{ m} = 48.248 \text{ m}$$

$$H = EL_{\text{energy}} - EL_{\text{dam crest}} = 48.248 \text{ m} - 43 \text{ m} = 5.248 \text{ m}$$

$$\frac{P}{H} = \frac{3.00 \text{ m}}{5.248 \text{ m}} = 0.57; C_o = 3.82 \text{ (from Figure 8)}$$

$$h_d = EL_{\text{energy}} - EL_{\text{TW}} = 48.248 \text{ m} - 47.50 \text{ m} = 6.748 \text{ m}$$

$$\frac{h_d}{H} = \frac{0.748 \text{ m}}{5.248 \text{ m}} = 0.142; \frac{h_d + d_{\text{supplied}}}{H} = \frac{0.748 \text{ m} + 7.50 \text{ m}}{5.248 \text{ m}} = 1.57$$

% Decrease = 16% (from Figure 9)

$$C_s = \frac{100 - \% \text{ Decrease}}{100} \times C_o = \frac{100 - 16}{100} \times 3.82 = 3.21$$

$$q_s = \frac{C_s}{1.811} \times H^{3/2} = \frac{3.21}{1.811} \times 5.248^{3/2} = 21.20 \frac{\text{m}^3/\text{s}}{\text{m}} > 13.70 \frac{\text{m}^3/\text{s}}{\text{m}} \text{ required}$$

**D.5.2.2** At afflux elevation of 47.80 m,

$$q_s = 17.40 \frac{\text{m}^3/\text{s}}{\text{m}} > 13.70 \frac{\text{m}^3/\text{s}}{\text{m}} \text{ required}$$

**d.5.2.3** At afflux elevation of 47.65 m,

$$q_s = 13.70 \frac{\text{m}^3/\text{s}}{\text{m}} = 13.70 \frac{\text{m}^3/\text{s}}{\text{m}} \text{ required}$$

Thus, afflux elevation = 47.65 m and energy elevation = 47.81 m

## **D.6 Hydraulic Jump Analysis and Determination of Length of Downstream Apron**

### **D.6.1 High Stage Flow**

**D.6.1.1** At  $d_1=1.50$  m

$$V_1 = \frac{q}{d_1} = \frac{13.70 \text{ m}^2/\text{s}}{1.50 \text{ m}} = 9.15 \text{ m/s}$$

$$h_{v1} = \frac{v_1^2}{2g} = \frac{(9.15 \text{ m/s})^2}{19.6 \text{ m/s}^2} = 4.27 \text{ m}$$

$$H_E = h_{v1} + d_1 = 4.27 \text{ m} + 1.50 \text{ m} = 5.77 \text{ m} < 7.814 \text{ m}$$

**D.6.1.2** At  $d_1=1.20$  m,

$$H_E = 7.82 \text{ m} \cong 7.814 \text{ m}$$

**D.6.1.3** Jump Height

$$d_2 = -\frac{d_1}{2} + \sqrt{\frac{d_1^2}{4} + \frac{2v_1^2 d_1}{g}} = -\frac{1.20}{2} + \sqrt{\frac{1.20^2}{4} + \frac{2(11.40)^2(1.20)}{9.81}}$$

$$d_2 = -0.60 + 5.70 = 5.10 \text{ m} < 7.50 \text{ m}$$

$$\frac{d_2 \text{ theoretical}}{d_2 \text{ supplied}} = \frac{5.10 \text{ m}}{7.50 \text{ m}} = 0.68; \text{ okay}$$

$$F = \frac{v_1}{\sqrt{gd_1}} = \frac{11.40 \text{ m/s}}{\sqrt{9.81 \times 1.20 \text{ m}}} = 3.32; \text{ Type 1 Basin}$$

**D.6.1.4** Length of Downstream Apron



$$L_a = 5(d_2 - d_1) = 5(5.10 \text{ m} - 1.20 \text{ m}) = 19.50 \text{ m} \approx 20.00 \text{ m}$$

#### D.6.1.5 Summary of Values for High Stage Flow

Parameter	Value
Q	3700 m <sup>3</sup> /s
EL <sub>TW</sub>	47.50 m
q <sub>required</sub>	13.70 m <sup>3</sup> /s/m
d <sub>supplied</sub>	7.50 m
EL <sub>energy</sub>	47.81 m
C <sub>o</sub>	3.82
C <sub>s</sub>	3.21
q	13.70 m <sup>3</sup> /s/m
d <sub>1</sub>	1.2 m
d <sub>2</sub>	5.1 m
F	3.32
L <sub>a</sub>	19.50 m

#### D.6.2 Low Stage Flow

D.6.2.1 For Q = 2500 m<sup>3</sup>/s, repeat procedure C.4 to C.6.

Parameter	Value
Q	2500 m <sup>3</sup> /s
EL <sub>TW</sub>	46.10 m
q <sub>required</sub>	9.25 m <sup>3</sup> /s/m
d <sub>supplied</sub>	6.10 m
EL <sub>energy</sub>	46.40 m
C <sub>o</sub>	3.835
C <sub>s</sub>	2.68
q	9.21 m <sup>3</sup> /s/m
d <sub>1</sub>	0.90 m
d <sub>2</sub>	4 m
F	3.48
L <sub>a</sub>	17.80 m

D.6.2.2 For Q = 1000 m<sup>3</sup>/s, repeat procedure C.4 to C.6.

Parameter	Value
Q	1000 m <sup>3</sup> /s
EL <sub>TW</sub>	43.20 m
q <sub>required</sub>	3.70 m <sup>3</sup> /s/m
d <sub>supplied</sub>	3.20 m
EL <sub>energy</sub>	44.55 m
C <sub>o</sub>	3.835
q	9.21 m <sup>3</sup> /s/m

d <sub>1</sub>	0.42 m
d <sub>2</sub>	2.39 m
F	4.35
L <sub>a</sub>	12.10 m

**D.6.2.3** Since the determined L<sub>a</sub> for low stage flow are less than 20 m, use L<sub>a</sub> = 20 m.

### D.7 Determination of the Extent of Riprap

$$L = c \times d_2 = 5.70 \times 5.10 \text{ m} = 29.10 \text{ m}$$

$$L_{Ra} = 1.5(L - L_a) = 1.5(29.10 - 20.00) = 13.65 \text{ m}$$

$$v_2 = \frac{q}{d_{\text{supplied}}} = \frac{13.70 \text{ m}^3/\text{s}/\text{m}}{7.50 \text{ m}} = 1.83 \frac{\text{m}}{\text{s}} = 6.00 \text{ ft/s}$$

$$L_{Rb} = \left( \frac{0.65H_0}{d_{\text{supplied}}} \right)^{\frac{3}{2}} \times v_2^2 = \left( \frac{0.65 \times 7.65}{7.50} \right)^{\frac{3}{2}} \times 6.00^2 = 19.50 \text{ ft}$$

$$L_R = \frac{L_{Ra} + \left( \frac{L_{Rb}}{3.28} \right)}{2} = \frac{13.65 \text{ m} + \frac{19.50 \text{ ft}}{3.28}}{2} = 9.80 \text{ m} \approx 10.00 \text{ m}$$

### D.8 Determination of the Size of Riprap

**D.8.1** Using the average tailwater velocity, V<sub>2</sub> and Figure 12, consider 6.3-in diameter or 12-lb riprap.

For Q = 3700 m<sup>3</sup>/s,

$$V_2 = \frac{q}{d_{\text{supplied}}} = \frac{13.70 \text{ m}^3/\text{s}/\text{m}}{7.50 \text{ m}} = 1.83 \frac{\text{m}}{\text{s}}$$

For Q = 2500 m<sup>3</sup>/s, V<sub>2</sub> = 1.52 m/s and for Q = 1000 m<sup>3</sup>/s, V<sub>2</sub> = 1.16 m/s.

**D.8.2** From the diameter, the weight can be calculated as follows:

$$W_R = \frac{4}{3} \pi r^3 \times 165 = \frac{4}{3} \pi \left( \frac{6.3}{2 \times 12} \right)^3 \times 165 = 12.23 \text{ lb}$$

For a greater factor of safety, use 10-in diameter or 50-lb riprap with gravel blanket underneath.

**D.8.3** The riprap thickness is 0.375 m ≈ 0.40 m while the gravel blanket thickness is 0.20 m.

### D.9 Determination of the Depth of the Downstream Cut-off Wall

<b>q (m<sup>3</sup>/s/m)</b>	<b>R (Depth of scour from Figure 14, m)</b>	<b>Required Depth of Downstream Cut-off Wall (m)</b>
13.70	7.62	0.12
9.25	5.80	-
3.70	3.35	1.15

From the tabulated values, 1.15 m governs. Considering a factor of safety, 8'00" steel sheet piles will be used.

#### **D.10 Determination of Crest Shape**

$$\frac{h_a}{H} = \frac{0.16}{4.81} = 0.033$$

$$X_c/H_o = 0.267 \text{ and } Y_c/H_o = 0.113$$

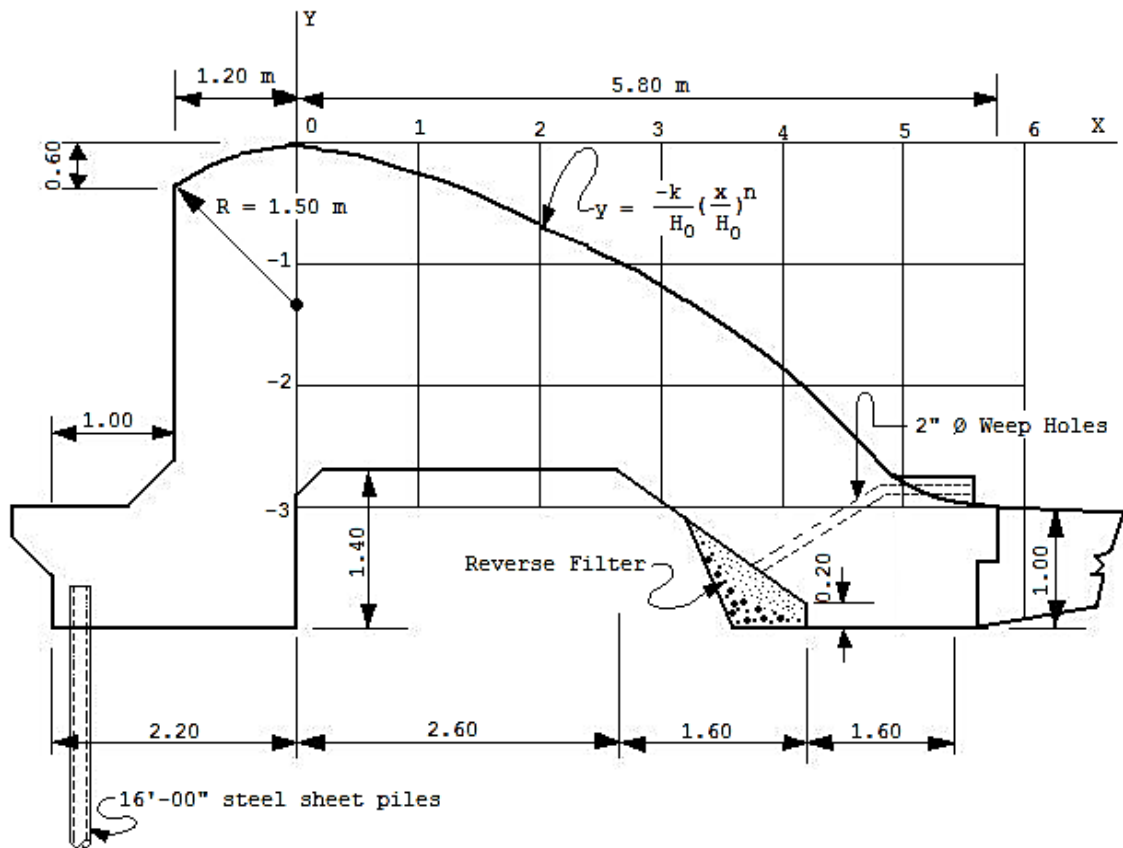
$$X_c = 1/4 H_o = 0.267 = 1/4 (4.81) = 1.20\text{m}$$

$$Y_c = 1/8 H_o = 1/8 (4.81) = 0.60\text{m}$$

$$y = 0.507H_o \left( \frac{x}{h_o} \right)^{1.855}$$

Filling up the plotting table,

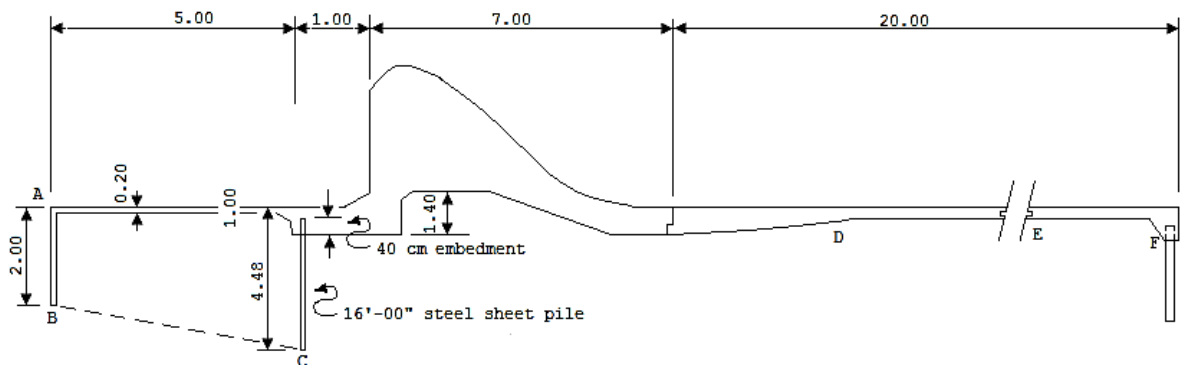
<b>x</b>	<b>x/H<sub>o</sub></b>	<b>(x/H<sub>o</sub>)<sup>n</sup></b>	<b>y</b>	<b>x</b>	<b>x/H<sub>o</sub></b>	<b>(x/H<sub>o</sub>)<sup>n</sup></b>	<b>y</b>
0.20	0.041	0.003	-0.007	2.40	0.500	0.280	-0.68
0.40	0.082	0.010	-0.024	2.60	0.540	0.320	-0.78
0.60	0.125	0.020	-0.049	2.80	0.580	0.370	-0.90
0.80	0.166	0.036	-0.087	3.00	0.620	0.410	-1.00
1.00	0.210	0.055	-0.134	3.40	0.700	0.520	-1.27
1.20	0.250	0.077	-0.187	3.80	0.790	0.650	-1.59
1.40	0.290	0.100	-0.244	4.00	0.830	0.710	-1.73
1.60	0.330	0.130	-0.320	4.40	0.910	0.840	-2.04
1.80	0.370	0.160	-0.390	4.80	0.997	1.000	-2.43
2.00	0.420	0.220	-0.490	5.00	1.030	1.056	-2.57
2.20	0.460	0.240	-0.590	5.40	1.120	1.230	-3.01



1st TRIAL SECTION

**D.11 Stability Analysis**

**D.11.1 Checking for short path condition,**

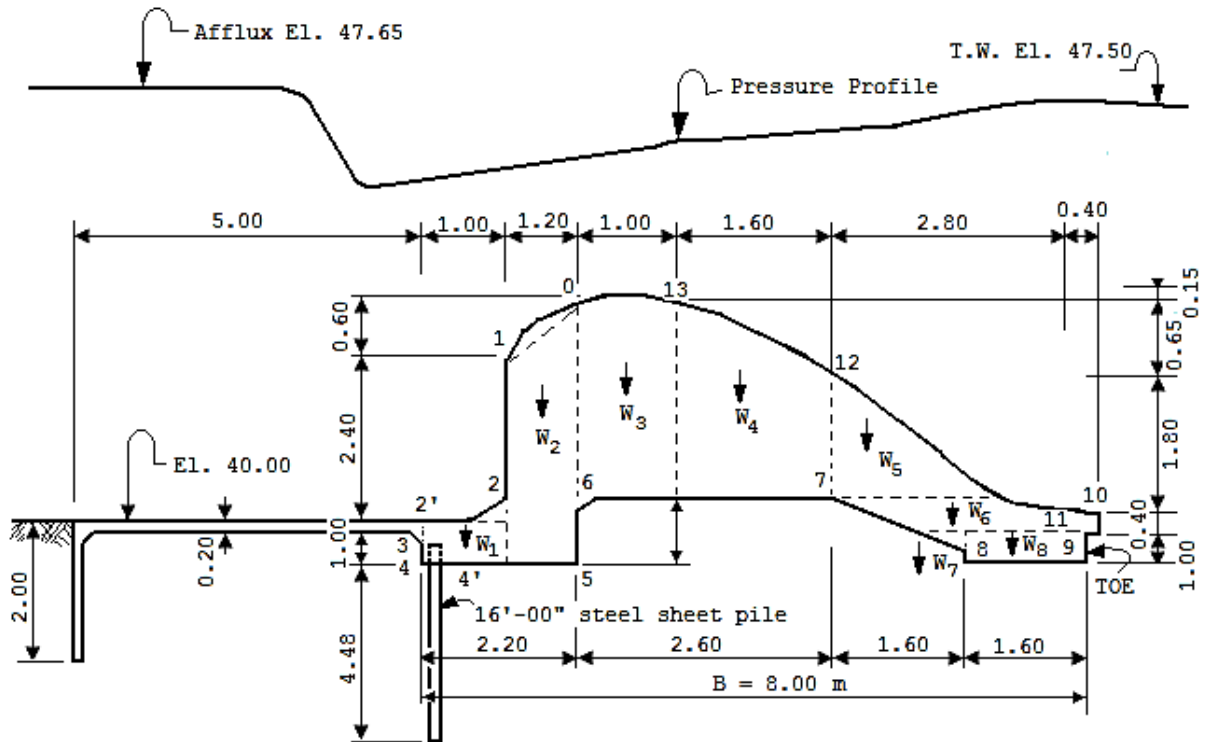


Length of creep from A to C =  $2.00 + 1.80 + 0.80 + 4.48 + (5.00/3) = 10.74$  m

Distance  $\overline{BC} = \sqrt{5.00^2 + 3.48^2} = \sqrt{37.20} = 6.10\text{m} > \frac{10.74}{2}$

Thus, there is no short path condition.

**D.11.2 Analyze under maximum flood condition.**



**D.11.2.1** Length of creep to point F = 2.00 + 1.80 + 0.80 + 4.48 + 1.60 + (13.00 + 20.00/3) = 26.16 m

**D.11.2.2** Pressure heads above the ogee crest:

Point	Distance from crest/ $H_0$	y	h
10	1.25	0.82 $H_0$	6.80
11	1.17	0.80 $H_0$	6.70
12	0.56	0.80 $H_0$	4.50
13	0.215	0.70 $H_0$	3.40
0	-	0.60 $H_0$	2.79
1	-	-	2.79

**D.11.2.3** Calculation for hydrostatic pressure on the dam

$$C = \frac{\text{Total Length of Creep}}{\text{Diff. in Water Levels}} = \frac{26.16}{0.15} = 174.00$$

Point	Length of Creep, $L_c$ (m)	Available Head (m)	Head loss, $L_c/c$	Net head, h (m)	Pressure, $P = 205 \text{ n (psf)}$
0	-	2.79	-	2.79	572
1	-	2.79	-	2.79	572
2	-	7.65	-	7.65	1,570
3	5.47	7.85	0.030	7.82	1,600

4	6.27	8.65	0.040	8.61	1,770
4	15.23	8.65	0.09	8.56	1,730
5	15.96	8.65	1.100	8.56	1,750
6	17.36	7.25	0.11	7.15	1,470
7	18.22	7.25	0.113	7.145	1,460
8	19.75	8.65	0.116	8.537	1,750
9	20.28	8.65	-	8.53	1,750
10	-	7.80	-	6.80	1,390
11	-	6.70	-	6.70	1,380
12	-	4.50	-	4.50	920
13	-	3.40	-	3.40	700

This value is a conservative assumption. It would still be safe to assume also that the pressure head at point (1) be equal to  $P_0 + 0.60$  m for this particular example.

External forces (lbs)	Lever arm (m)	Moment about toe (m-lbs)	
		Righting	Overturning
$= (572)(1.20)(3.28) = 2,251 \downarrow$	$5.80 + (120)/2 = 6.40$	14,406 ↻	
$= [(572+1570)/2](3.00)(3.28)$ $= 10,539 \rightarrow$	$1.00 + (3.00/3)[(1570+1144)/2140] = 2.26$		23,818 ↻
$(1570)(1.00)(3.28) = 5150 \downarrow$	$7.00 + (1.00/2) = 7.50$	38,625 ↻	
$[(1600+1770)/2](0.80)(3.28) =$ $4,421 \rightarrow$	$(0.80/3)[(1770+3200)/3370] =$ $0.345$		1,525 ↻
$(1750)(2.20)(3.28) = 12,628 \uparrow$	$5.80 + (2.20/2) = 6.90$		87,133 ↻
$[(1750+1470)/2](1.40)(3.28) =$ $7,393 \leftarrow$	$(1.40/3)[(1750+2940)/3220] = 0.68$	5,027 ↻	
$[(1470+1460)/2](2.60)(3.28) =$ $12,493 \uparrow$	$3.20 + (2.60/3)[(1460+2940)/2930] = 4.50$		56,218 ↻
$[(1460+1750)/2](1.40)(3.28) =$ $8,423$	$1.60 + (1.60/3)[(1750+2920)/3210] = 2.38$		20,047 ↻
$[(1460+1750)/2](1.40)(3.28) =$ $7,370 \rightarrow$	$(1.40/3)[(1750+2920)/3210] = 0.68$		5,012 ↻
$(1750)(1.60)(3.28) = 9,184 \uparrow$	$(1.60/2) = 0.80$		7,347 ↻
$[(1390+1380)/2](90.40)(3.28) = 1,817$ $\downarrow$	$(0.40/3)[(1390+2760)/2770] = 0.20$	363 ↻	
$[(1380+920)/2](2.80)(3.28) =$ $10,562 \downarrow$	$0.40 + (2.80/3)[(1380+1840)/2300] = 1.71$	18,061 ↻	
$\{(1380+920)/2\}(2.20)(3.28) =$ $2,533 \leftarrow$	$1.00 + (2.20/3)[(1380+1840)/2300] = 2.03$	5,142 ↻	
$[(920+700)/2](1.60)(3.28) =$ $4,251 \downarrow$	$3.20 + (1.60/3)[(920+1400)/1620] = 3.70$	15,728 ↻	
$[(920+700)/2](0.65)(3.28) =$ $1,727 \leftarrow$	$3.20 + (0.65/3)[(920+1400)/1620] = 3.40$	5,872 ↻	
$[(700+572)/2](1.00)(3.28) =$ $2,086 \downarrow$	$4.80 + (1.00/3)[(700+1144)/1272] = 5.28$	11,014 ↻	
$[(700+572)/2](0.15)(3.28) =$ $313 \leftarrow$	$3.85 + (0.15/3)[(700+1144)/1272] = 3.92$	1,227 ↻	

$$\Sigma M_R = 115,465; \Sigma M_O = 201,100; \Sigma F_V = 16,611; \Sigma F_H = 10,364$$

Weight per ft. Strip (lbs)	Lever arm (m)	Moment about toe (m-lbs)	
		Righting	Overturning
$(1.00)(1.00)(1,615) = 1,615 \downarrow$	$7.00 + (1.00/2) = 7.50$	12,113 ↻	
$[(3.40+4.00)/2](1.20)(1,615) =$ $7,171 \downarrow$	$5.80 + (1.20/3)[(4.00+6.80)/7.40] =$ $6.38$	45,750 ↻	
$[(2.60+2.45)/2](1.00)(1,615) =$ $4,078 \downarrow$	$4.80 + (1.00/3)[(2.15+5.20)/5.05] =$ $5.30$	21,613 ↻	
$[(2.45+1.80)/2](1.60)(1,615) =$ $5,491 \downarrow$	$3.20 + (1.60/3)[(1.82+4.90)/4.25] =$ $4.04$	22,184 ↻	
$(1/2)(1.80)(2.40)(1,615) =$ $3,468 \downarrow$	$0.80 + (2/3)(2.40) = 2.40$	8,371 ↻	
$(2.40)(0.40)(1,615) = 1,550 \downarrow$	$0.80 + 1.10 = 1.90$	2,945 ↻	
$(1/2)(1.10)(0.80)(1,615) = 710 \downarrow$	$1.60 + (1.60/3) = 2.13$	1,512 ↻	
$(1.60)(1.00)(1,615) = 2,584 \downarrow$	$(1.60/2) = 0.80$	2,067 ↻	

$$\Sigma W = 26,687; \Sigma M_w = 116,555$$

SUMMARY:  $\Sigma M = 115465 + 116555 - 201100 = 30920 \text{ m} - \text{lb} \curvearrowright$

$\Sigma V = 26687 + 16111 - 10,567 \text{ lb} \downarrow$

$\Sigma H = \Sigma FH = 10364 \text{ lb} \rightarrow$

$\bar{x} = \frac{\Sigma M}{\Sigma V} = \frac{30920}{10567} = 2.92\text{m} < \frac{800}{3}$  (within the middle third) OK

$e = \frac{B}{2} - \bar{x} = 4.00 - 2.92 = 1.08\text{m}$

#### D.11.2.4 Foundation reactions

$E_{\text{toe}} = \frac{\Sigma V}{B} \left(1 + \frac{6e}{B}\right) = \frac{10567}{8.00 \times 3.28} \left(1 + \frac{6 \times 1.08}{8.00}\right) = 729 \text{ psf} < 2000$

$f_{\text{heel}} = \frac{\Sigma V}{B} \left(1 - \frac{6e}{B}\right) = (403)(0.19) = 77 \text{ psf OK safe}$

Factor of Safety against Overturning =  $\frac{\Sigma MR}{\Sigma Mo} = \frac{232020}{201100} = 1.18 < 1.5$  unsafe

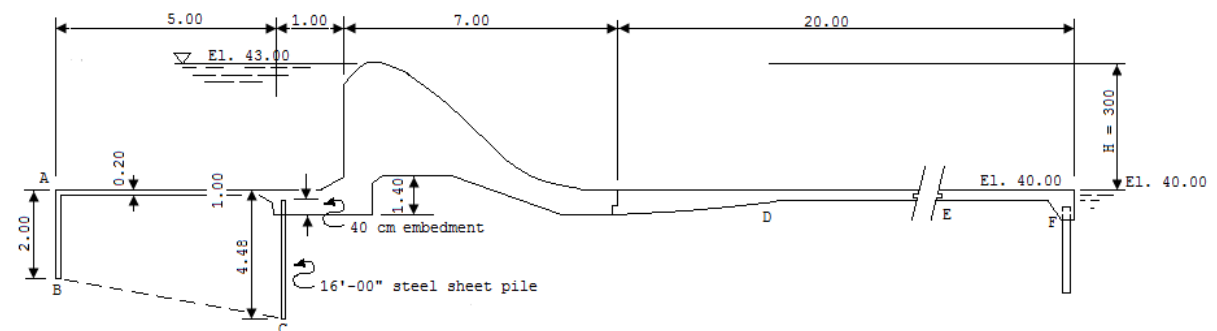
Sliding Factor =  $\frac{\Sigma M}{\Sigma V} = \frac{10364}{10567} = 0.97 >$

0.4 maximum allowable for Gravel and Sand

#### D.11.2.5 Recommendation

The first trial section should be modified, say lowering further the middle portion of the base to attain additional weight and then stability analysis shall be made for new section and repeated if necessary until the dam is found to have adequate factors of safety.

#### D.11.3 Analyze under normal operation condition.



For the purpose of illustration, adopt the first trial section in the stability analysis for this condition in order to have additional factor of safety, it will be assumed that the weep holes are all clogged up and the upstream water surface is in level with the dam crest (El. 43.00) while the tailwater elevation is flushed with the downstream apron floor is, El. 40.00.



**D.11.3.1** Length of creep to point F = 2.00 + 1.80 + 0.80 + 4.48 + 1.60 + (13.00 + 20.00/3) = 26.16 m

$$C = \frac{\text{total length of creep}}{\text{diff. in water levels}} = \frac{26.16}{3.00} = 8.72 > 5 \text{ for coarse sand OK}$$

**D.11.3.2** Calculation for hydrostatic pressure on the dam

Point	Length Of creep L <sub>c</sub> (m)	Available Head (m)	Head loss, L <sub>c</sub> /c (m)	Net head, h (m)	Pressure, P = 205 n (psf)
0	---	0.00	---	0.00	0.00
1	---	0.60	---	0.60	123
2	---	3.00	---	3.00	615
2	---	3.00	---	3.00	615
3	5.47	3.20	0.62	2.58	528
4	6.27	4.00	0.72	3.28	670
4	15.23	4.00	1.75	2.25	460
5	15.96	4.00	1.82	2.18	448
6	17.36	2.60	1.98	0.62	127
7	18.22	2.60	2.09	0.51	104
8	19.75	4.00	2.26	1.74	356
9	20.28	4.00	2.32	1.68	345

External Forces (lbs)	Lever arm (m)	Moment about toe (m-lbs)	
		Righting	Overtur ning
(1/2)(123)(1.20)(3.28)= 242 ↓	5.60+(2/3)(1.20)=6.60	1,597 ↻	
(1/2)(615)(3.00)(3.28)= 3,025	1.00+91/3)(3.00)=2.00		6,050 ↻
(615)(1.00)(3.28)=2,028 ↓	7.00+(1.00/2)=7.50	15,200 ↻	
[(528+670)/2](0.80)(3.28)= 1,570 →	(0.80/3)[(670+1086)/1198]= 0.39		610 ↻
[(460+448)/2](2.20)(3.28)= 3,260 ↑	5.80+(2.20/3)[(448+920)/908 ]=6.91		22,600 ↻
[(448+127)/2](1.40)(3.28)= 1,480 ←	(1.40/3)[(448+254)/575]=0.5 7	840 ↻	
[(127+104)/2](2.60)(3.28)= 980 ↑	3.20+(2.60/3)[(104+254)/231 ]=4.54		4,450 ↻
[(104+356)/2](1.60)(3.28)= 1,210 ↑	1.60+(1.60/3)[(356+208)/460 ]=2.26		2,730 ↻
[(104+356)/2](1.40)(3.28)= 1,060 →	(1.40/3)[(356+208)/460]=0.5 7		605 ↻
[(356+345)/2](1.60)(3.28)= 1,840 ↑	(1.60/3)[(345+712)/701]=0.8 0		1,480 ↻

$$\Sigma M_R = 17,637; \Sigma M_o = 38,525; \Sigma F_v = 5,028 \uparrow; \Sigma F_H = 4,175 \rightarrow$$

$$\Sigma W = 26,687 \text{ lb } \downarrow; \Sigma M_w = 116,555 \text{ m-lb } \curvearrowright$$

SUMMARY:  $\Sigma M = 17637 + 116555 - 38525 = 95667 \text{ m} - \text{lb } \curvearrowright$

$$\Sigma V = 26687 - 5028 = 21659 \text{ lb } \downarrow$$

$$\Sigma H = F = 4175 \text{ lb } \rightarrow$$

$$\bar{x} = \frac{\Sigma M}{\Sigma V} = \frac{95667}{21656} = 4.46 \text{ m (within the middle third)}$$

$$e = \frac{B}{2} - \bar{x} = 4.00 - 4.46 \text{ m} = 0.46 \text{ m}$$

### D.11.3.3 Foundation reactions

$$E_{\text{toe}} = \frac{\Sigma V}{B} \left(1 - \frac{6e}{B}\right) = \frac{21659}{8.00 \times 3.28} \left(1 + \frac{6 \times 0.46}{8.00}\right)$$

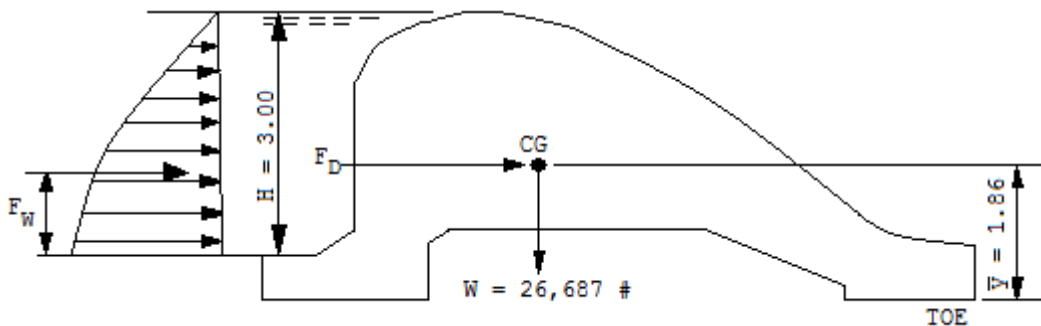
$$f_{\text{heel}} = \frac{\Sigma V}{B} \left(1 + \frac{6e}{B}\right) = (825)(1.345) = 1110 \text{ psf} < 2000 \text{ safe}$$

$$\text{FS against overturning} = \frac{\Sigma M}{M} = \frac{134192}{38525} = 4.48 > 1.5 \text{ very safe}$$

$$\text{Sliding Factor} = \frac{\Sigma H}{\Sigma V} = \frac{4175}{21656} = 0.19 < 0.4 \text{ safe}$$

### D.11.4 Analyze under normal operation condition but with seismic forces.

#### D.11.4.1 Calculation for earthquake forces



#### D.11.4.1.1 Lateral force Due to Dam Weight Using horizontal Acceleration, or 0.15g

$$F_D = \frac{W}{g} a = \frac{W}{g} (0.15g) = 0.15W = (0.15)(26687) = 4003 \text{ lb } \rightarrow$$

$$M_{\text{toe}} = (4003)(1.86) = 7446 \text{ m} - \text{lb}$$

#### D.11.4.1.2 Lateral Force Due to Hydrodynamic Force

$$F_w = 0.583H^{2.00}/g$$

$$F_w = (0.583)(0.15)(62.5)H^2 = 5.49H^2 = (5.49)(3.00 \times 3.28)^2 = 522 \text{ lb} \rightarrow$$

$$M_{\text{toe}} = (522)(1.00 + 4 \times 3.00) = (522)(2.20) = 1148 \text{ m} - \text{lb} \cup$$

#### D.11.4.1.3 Combine with D.10.3,

$$\Sigma M_R = 17637 + 116555 = 134192 \text{ m} - \text{lb} \cup$$

$$\Sigma M_O = 38525 + 7446 + 1148 = 47119 \text{ m} - \text{lb} \cup$$

$$\therefore \Sigma M = 87073 \text{ m} - \text{lb} \cup$$

$$\Sigma V = 21659 \text{ lb}$$

$$\Sigma H = 4175 + 4003 + 522 = 8800 \text{ lb} \rightarrow$$

$$\therefore \bar{x} = \frac{\Sigma M}{\Sigma V} = \frac{87073}{21659} = 4.02 \text{ m (within the middle third) OK}$$

$$e = \frac{B}{2} - \bar{x} = 4.00 - 4.02 \text{ m} = -0.02$$

#### D.11.4.1.4 Foundation reaction

$$E_{\text{toe}} = \frac{\Sigma V}{B} \left(1 - \frac{6e}{B}\right) = \frac{21659}{8.00 \times 3.28} \left(1 - \frac{6 \times 0.02}{8.00}\right) = (825)(1 - 0.015) = 812 \text{ psf}$$

$$f_{\text{heel}} = \frac{\Sigma V}{B} \left(1 + \frac{6e}{B}\right) = (825)(1.015) = 835 \text{ psf OK safe}$$

$$\text{FS against overturning} = \frac{\Sigma M_R}{\Sigma M_O} = \frac{134192}{47119} = 2.86 > 1.5 \text{ safe}$$

$$\text{Sliding Factor} = \frac{\Sigma H}{\Sigma V} = \frac{8800}{21656} = 0.405 \approx 0.40 \text{ failry OK}$$

#### D.11.5 Analyze under construction condition.

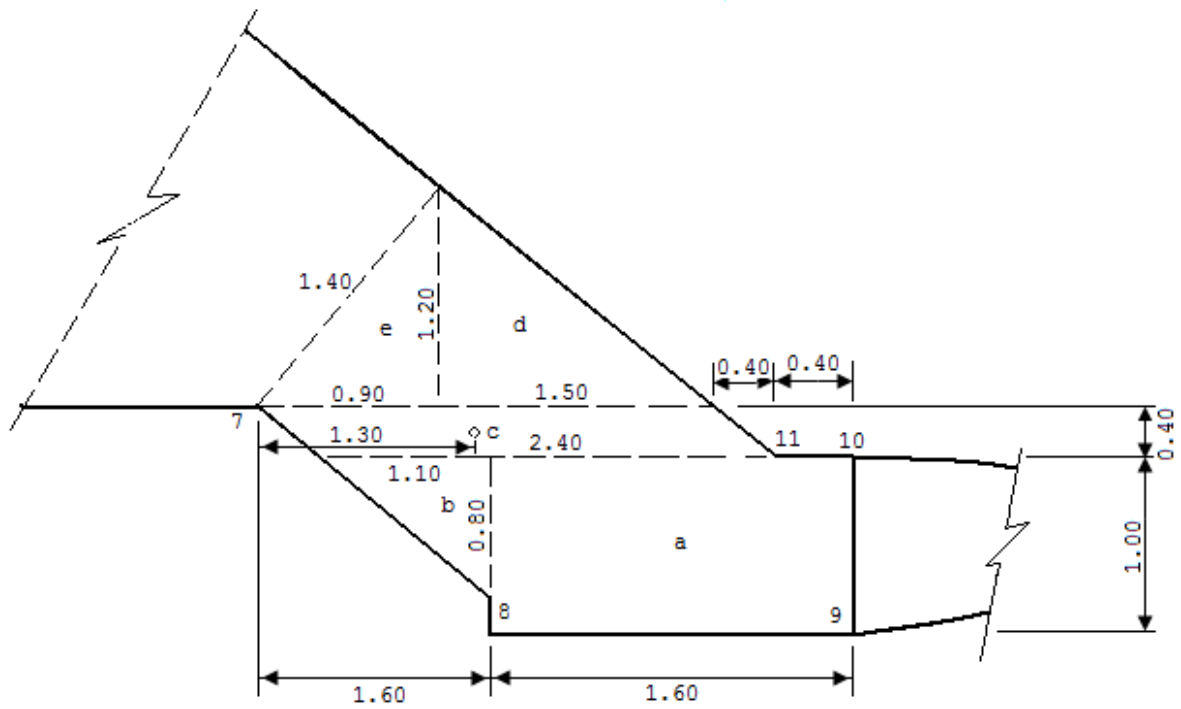
$$\bar{x} = \frac{\Sigma M_W}{\Sigma W} = \frac{116555}{26687} = 4.37 \text{ m (within the middle third) OK}$$

$$e = \frac{B}{2} - \bar{x} = 4.00 - 4.37 \text{ m} = -0.37$$

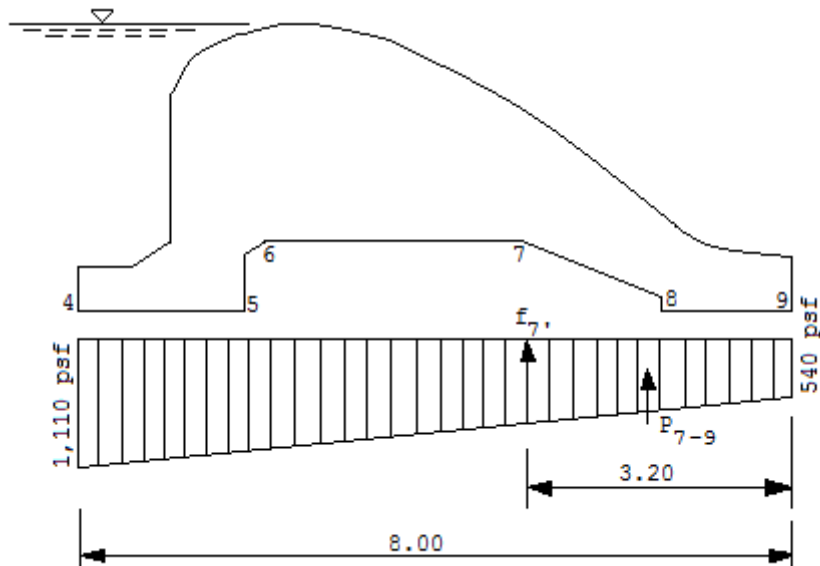
$$f_{\text{heel}} = \frac{\Sigma W}{B} \left(1 + \frac{6e}{B}\right) = \frac{26687}{8.00 \times 3.28} \left(1 + \frac{6 \times 0.37}{8.00}\right) = 1310 \text{ psf} < 2000 \text{ safe}$$

$$F_{\text{toe}} = \frac{\Sigma V}{B} \left(1 - \frac{6e}{B}\right) = (1020) = 730 \text{ psf}$$

**D.11.6** Determine tensile reinforcement at point 7 of the dam section due to uplift during normal operation condition.



**D.11.6.1** Calculate foundation reaction at point 7.



$$f_{7,} = 540 + \frac{3.20}{5.00} = (570) = 540 + 228 = 768 \text{ psf}$$

Under D.10.3, hydrostatic pressures at point (7)(8)(9) are as follows:

$$P_7 = 104 \text{ psf}; \quad P_8 = 356 \text{ psf}; \quad P_9 = 345 \text{ psf}$$

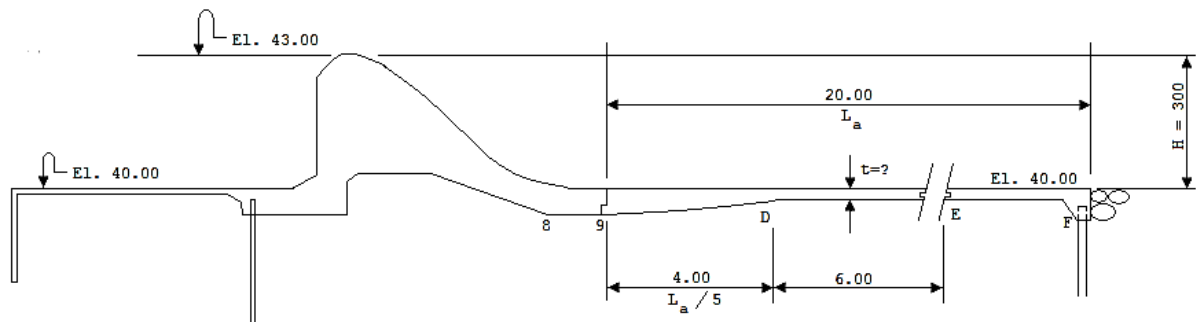
Forces and/or weights (lbs)	Lever arm (m)	Moment about toe (m-lbs)	
		Righting	Overturning
$P_{7-8V}$ $=[(104+356)/2](1.60)(3.28)=1,207$ $\rightarrow$	$(1.60/3)[(104+712)/460]=0.95$		1,147 ↻
$P_{7-8H}$ $=[(104+356)/2](1.40)(3.28)=1,056$ $\uparrow$	$(1.40/3)[(104+712)/460]=0.83$		876 ↻
$P_{8-9}$ $=[(356+345)/2](1.60)(3.28)=1,839$ $\uparrow$	$1.60+(1.60/3)[(356+690)/701]=2.40$		4,414 ↻
$P_{7-9}$ $=[(768+540)/2](3.20)(3.28)=6,864$ $\uparrow$	$(3.20/3)[(768+1080)/1308]=1.51$		10,365 ↻
$W_a=(1.60)(1.00)(1615)=2,584 \downarrow$	$1.60+(1.60/2)=2.40$	6,202 ↻	
$W_b=((1/2)(1.10)(0.80)(1615)=710$ $\downarrow$	$1.60-(1.10/2)=1.23$	873 ↻	
$W_c=(2.40)(0.40)(1615)=1,550 \downarrow$	1.30	2,015 ↻	
$W_d=(1/2)(1.50)(1.20)(1615)=1,454$ $\downarrow$	$0.90+(1.50/3)=1.45$	2,108 ↻	
$W_e=(1/2)(0.90)(1.20)(1615)=872 \downarrow$	$(2/3)(0.90)=0.60$	532 ↻	

$$\sum M_R = 11,730; \sum M_O = 16,802$$

$$M = 16802 - 11730 = 5072 \text{ m} - \text{lb or } 16636 \text{ ft} - \text{lb}$$

$$d = 1.40 - 0.07 = 1.33 \text{ m or } 52''$$

**D.11.7** Determine the thickness of downstream apron.



$$C = \frac{26.16}{3.00} = 8.72$$

Point	Length of Creep, Lc (m)	Head Loss, H <sub>L</sub> = L <sub>c</sub> /C (m)	Net head, H <sub>net</sub> = H - H <sub>L</sub>	Effective head, h (ft)	Equation: t-w <sub>c</sub> = (4/3)wh
9	20.28	2.32	0.68	2.23 + t <sub>9</sub>	t <sub>9</sub> x 150 = (4/3)(62.5)(2.23+t <sub>9</sub> )
D	21.61	2.48	0.52	1.70 + t <sub>D</sub>	t <sub>D</sub> x 150 = (4/3)(62.5)(1.70+t <sub>D</sub> )
E	24.61	2.85	0.15	0.49 + t <sub>E</sub>	t <sub>E</sub> x 150 = (4/3)(62.5)(0.49+t <sub>E</sub> )

$$t_9 = \frac{4}{3} \times \frac{62.5}{150} = (2.23 + t_9) = 0.555(2.23 + t_9) = 1.239 + 0.555t_9$$

$$0.445t_9 = 1.239; \quad t_9 = \frac{1.239}{0.445} = 2.78 \text{ ft. or } 0.85\text{m}; \quad \text{USE } t_9 = 1.00$$

$$t_D = 0.555(1.70 + t_D) = 0.943 + 0.555 t_D; \quad t_D = \frac{0.943}{0.445} = 2.12 \text{ ft. or } 0.65\text{m}$$

$$t_E = 0.555(0.49 + t_E) = 0.272 + 0.555 t_E; \quad t_E = \frac{0.272}{0.445} = 0.61 \text{ ft. or } 0.19\text{m}$$

Use 0.30m (min.)

**Technical Working Group (TWG) for the Development of Philippine  
National Standard for Design of a Diversion Dam**

***Chair***

**Engr. Bonifacio S. Labiano**  
National Irrigation Administration

***Members***

**Engr. Felimar M. Torizo**  
Board of Agricultural Engineering  
Professional Regulation Commission

**Dr. Teresita S. Sandoval**  
Bureau of Soils and Water Management  
Department of Agriculture

**Dr. Armando N. Espino Jr.**  
Central Luzon State University

**Dr. Elmer D. Castillo**  
Philippine Society of Agricultural Engineers

**Dr. Roger A. Luyun Jr.**  
University of the Philippines Los Baños

**Engr. Francia M. Macalintal**  
Philippine Council for Agriculture and Fisheries  
Department of Agriculture

***Project Managers***

**Engr. Darwin C. Aranguren**

**Engr. Romulo E. Eusebio**

**Engr. Mary Louise P. Pascual**

**Engr. Fidelina T. Flores**

**Engr. Marie Jehosa B. Reyes**

**Ms. Micah L. Araño**

**Ms. Caroline D. Lat**

**Mr. Gerald S. Trinidad**

University of the Philippines Los Baños –  
Agricultural Machinery Testing and Evaluation Center