

**PHILIPPINE
NATIONAL
STANDARD**

**PNS/BAFS 332:2022
ICS 65.060.40**

Knapsack Sprayer – Methods of Test



BUREAU OF AGRICULTURE AND FISHERIES STANDARDS

BPI Compound Visayas Avenue, Diliman, Quezon City 1101 Philippines

Trunkline: (632) 928-8741 to 64 loc. 3301-3319

E-mail: bafs@da.gov.ph

Website: www.bafs.da.gov.ph

Table of contents

Foreword	iii
1 Scope.....	1
2 Normative References	1
3 Terms and Definitions	2
4 General Conditions for Test	2
4.1 Selection of knapsack sprayer to be tested	2
4.2 Role of the test applicant	2
4.3 Role of the representative of the test applicant.....	2
4.4 Role of test engineer.....	2
4.5 Test site conditions	2
4.6 Suspension/termination of test.....	2
5 Test Preparation	3
5.1 Preparation of the knapsack sprayer for testing.....	3
5.2 Test instruments and other materials.....	3
5.3 Test materials	3
6 Verification of Manufacturer’s Technical Data and Information	3
7 Performance Test	3
7.1 Engine as prime mover	3
7.2 Battery capacity test for electric motor-driven type	4
7.3 Volumetric efficiency	4
7.4 Leak.....	5
7.5 Tilt and inversion.....	5
7.6 Nozzle performance.....	5
7.7 Cut-off Valve Reliability	7
7.8 Pressure test.....	8
7.9 Continuous running test.....	8
7.10 Strap	9
7.11 Drop test	10
7.12 Ease of operation.....	11
7.13 Operators’ safety	11
7.14 Data recording and observations	12
8 Presentation of Results.....	12
9 Formula.....	12
10 Test Report	12
Annex A.....	14
Annex B.....	15
Annex C	18
Annex D	22
Bibliography	23

Foreword

In 2016, the Philippine Council for Agriculture and Fisheries (PCAF)-Agricultural and Fishery Mechanization Committee (AFMeC) issued Resolution No. 6, series of 2016 (Endorsing to the DA Secretary through the BAFS the Identified Agricultural Fisheries Machinery, Equipment and Infrastructures for Philippine Agricultural Engineering Standards [PAES]/ PNS Development and Updating) endorsing the revision of the PAES on Lever-Operated Knapsack Sprayer – Specifications (PAES 112:2000) and Methods of Test (PAES 113:2000). The purpose of the revision is to update the standards to reflect current technologies on knapsack sprayer and address procurement challenges.

In response, the Bureau of Agriculture and Fisheries Standards (BAFS) conducted a Focus Group Discussion (FGD) in 2018 to discuss the major issues on knapsack sprayer. A Technical Working Group (TWG) was then created to revise the PNS under Special Order (SO) No. 1092 series of 2018 (Creation of Technical Committees and its TWGs for the Development of PNS for Agriculture and Fisheries Products and Machinery, Tools, and Equipment). This was later amended and updated through SO No. 817 series of 2021 (Addendum to Special Order 81, Series of 2021 Entitled, “Creation of TWG for the Development of PNS for Agriculture and Fishery Products, Machinery, and Equipment”) and SO No. 103, series of 2022 (Creation of TWG for the Development of PNS for Agriculture and Fishery Products, Machineries, and Infrastructure). The TWG is composed of representatives from relevant DA agencies, other National Government Agencies (NGAs), academe, research institution, private sector, and Civil Society Organizations (CSOs).

TWG meetings were conducted for the period October 2019 to May 2020. The TWG agreed to delay the discussion of the PNS, taking into consideration the then revision of the major ISO reference documents in 2020, which are the ISO 19932-1:2013 (Equipment for crop protection — Knapsack sprayers — Part 1: Safety and environmental requirements) and ISO 19932-2:2013 (Equipment for crop protection — Knapsack sprayers — Part 2: Test methods). In September 2021, the drafting of the PNS resumed after the revision of ISO references was canceled. The draft PNS underwent a series of TWG meetings and stakeholder consultations conducted via blended platforms. In May 2022, the Philippine Council for Agriculture and Fisheries (PCAF) – Committee on Agricultural and Fisheries Mechanization (CAFMech) also recommended for the approval of the final draft PNS through the issuance of Resolution No. 35, series of 2022 (Recommending to the DA Secretary the Approval of the Final Drafts of the PNS for Knapsack Sprayer – Specifications and Methods of Test and the PNS on Technical Means for Ensuring Safety – Guidelines). The final draft PNS was subsequently endorsed to the DA Secretary for approval.

This BAFS/PNS edition includes the following significant changes relative to the previous PAES 113:2000:

- a) Modification of the scope;
- b) Inclusion of the clause for General conditions of the test, Test preparation, Presentation of results, Formula, and Test report;
- c) Adoption of the methods of test for “pressure test”, “cut-off valve reliability”, “strap drop test”, “strap absorbency test”, and “drop test” from ISO 19932-2:2013 (Equipment for crop protection — Knapsack sprayers — Part 2: Test Methods); and
- d) Inclusion of “Battery capacity test for electric motor-driven type knapsack sprayer”, “Spray angle determination test”, and “Measuring spray droplet size test”.

This Standard cancels and replaces PAES 113:2000 (Lever-operated knapsack sprayer — Methods of Test). This PNS was drafted in accordance with the editorial rules of the ISO/IEC Directives, Part 2.

1 Scope

This standard specifies the methods of test for the knapsack sprayer used in agricultural production. Specifically, it shall be used to:

- a) verify the mechanism, main dimensions, materials of construction, accessories of the knapsack sprayer, and the list of specifications submitted by the manufacturer;
- b) determine the performance and durability of the knapsack sprayer;
- c) evaluate the ease of handling and safety features; and
- d) report the results of the tests.

2 Normative References

The following documents are referred to in the text in such a way that some or all their content constitutes the requirements of this document. The latest edition of the referenced document (including any amendments) applies.

AMTEC - UPLB. (2000). Agricultural machinery — Method of sampling (PAES 103:2000). <https://amtec.ceat.uplb.edu.ph/wp-content/uploads/2019/07/PAES-103-2000-Agricultural-Machinery-Method-of-Sampling.pdf>

Bureau of Agriculture and Fisheries Standards (BAFS). (2022). Agricultural and fisheries machinery — Knapsack sprayer — Specifications (PNS/BAFS 331:2022)

3 Terms and Definitions

For the purpose of this Standard, the terms and definition stated under PNS/BAFS 331:2022 (Knapsack Sprayer — Specifications) shall apply.

4 General Conditions for Test

4.1 Selection of knapsack sprayer to be tested

Knapsack sprayer submitted for testing shall be sampled in accordance with PAES 103:2000 (Agricultural machinery — Methods of sampling) or any other suitable method of selection.

4.2 Role of the test applicant

The test applicant shall submit specifications and other relevant information about the knapsack sprayer. They shall abide with the terms and conditions set forth by the official testing agency, provide testing materials, and shoulder other variable costs to carry out the test.

4.3 Role of the representative of the test applicant

An officially designated representative of the test applicant shall be skilled, able to demonstrate, adjust, repair as the case may be, and decide on matters related to the operation of the knapsack sprayer.

4.4 Role of test engineer

The certified test engineer shall lead the conduct of the performance testing in accordance with the provisions of this standard. Furthermore, the test engineer shall oversee other relevant activities prior to and after the conduct of the testing.

4.5 Test site conditions

The site should have ample provisions for material handling, temporary storage, workspace, and suitable for normal working condition. Adequate ventilation and lighting shall be provided in the area.

4.6 Suspension/termination of test

If during the test run, the knapsack sprayer stops due to breakdown or malfunction that affects its performance, the test shall be suspended. If the equipment is unable to continue operation, the test shall be terminated.

5 Test Preparation

5.1 Preparation of the knapsack sprayer for testing

5.1.1 The representative of the test applicant and testing agency shall check the knapsack sprayer to ensure that it has been operated in accordance with the instruction of the manufacturer. The official testing agency shall test the knapsack sprayer in accordance with the rated operating pressure. If there is no indicated rated operating pressure, 275 kPa shall be used.

5.1.2 The knapsack sprayer shall be tested for normal operation, as stated in the operators' manual.

5.2 Test instruments and other materials

The suggested list of minimum laboratory test equipment and materials needed to carry out the knapsack sprayer test is shown in Annex A (Minimum list of laboratory test equipment and materials). These instruments shall be calibrated regularly. These instruments shall be physically checked for operation and shall be cleaned before and after each test. A checklist of instruments and materials to be used before departure to and from the testing area shall be prepared.

5.3 Test materials

The knapsack sprayer shall be tested using a clean and solid-free tap water.

6 Verification of Manufacturer's Technical Data and Information

6.1 A plain and level surface shall be used as reference plane for verification of dimensions.

6.2 The items to be inspected and verified shall be recorded in Annex B (Specifications of knapsack sprayer).

7 Performance Test

7.1 Engine as prime mover

7.1.1 Fuel consumption

To get the amount of fuel consumed, refill method shall be used. The tank shall be filled to full capacity or to a certain level before the test. After each test, the tank shall be refilled with measured volume of fuel. When filling up the fuel tank, extra attention shall be paid to keep it horizontal and to ensure that no unfilled space is left inside.

7.1.2 Noise level

7.1.2.1 The sound emitted by the machine, with and without load, shall be measured using a sound level meter. The noise level, expressed in decibel [dB (A)], shall be measured 50 mm away from the ear level of the operator/s.

7.1.2.2 For each data to be taken, there shall be a minimum of five observations. Before taking data, the test engineers shall ensure that the speed, and other functional characteristics have stabilized. The time of recording shall be properly spaced during the whole duration of the test trial.

7.1.2.3 Speed of components

The speed of the rotating shafts of the major components of the knapsack sprayer with and without loads shall be taken using a tachometer. Requirements for each data to be taken shall conform to 7.1.2.2.

7.2 Battery capacity test for electric motor-driven type

7.2.1 The battery capacity test is carried out to evaluate the operating performance and to examine if any abnormality or trouble arises during continuous operation.

7.2.2 The battery of the sprayer shall be fully charged prior to starting the battery capacity test.

7.2.3 The sprayer shall be set at its maximum discharge setting.

7.2.4 The sprayer shall be run continuously until the sprayer stopped operation due to low battery level. The pressure, volume of water discharged, voltage, and current shall be measured every hour.

7.2.5 The nozzle used shall be noted. Only one type of nozzle shall be used for the whole duration of test.

7.3 Volumetric efficiency

7.3.1 General

7.3.1.1 This is carried out to determine the ratio of the actual volume of fluid discharge to that of the piston or plunger displacement in one stroke.

7.3.1.2 The sprayer shall be filled with clean tap water to its tank capacity.

7.3.1.3 A pressure gauge shall be fitted as close to the nozzle as possible to monitor the rated operating pressure.

7.3.1.4 There shall be a minimum of five observations for each data obtained.

7.3.2 Actual volume discharge per stroke determination

With the set-up indicated in 7.3.1, the sprayer shall be operated at rated operating pressure. Upon the stabilization of pressure, the discharge in 20 successive full strokes sustaining the rated operating pressure shall be collected and measured using a graduated cylinder.

7.4 Leak

7.4.1 This test shall be carried out to check the effectiveness of the one-way valve, seals, and cut-off valve connections.

7.4.2 Nozzle shall be removed and replaced with a pressure gauge.

7.4.3 The sprayer shall be pressurized to 1.75 times the rated operating pressure after which pumping action shall be stopped and the change in pressure after a period of one hour shall be noted and reported.

7.4.4 Three trials shall be made with three different operators to assemble the lance assembly without the use of tools.

7.5 Tilt and inversion

7.5.1 Tilt and inversion shall be carried out to check for any leak on the sprayer when tilted and inverted.

7.5.2 The sprayer shall be filled with clean tap water and shall be tilted at 45° angle and at horizontal position for five minutes on each side.

7.5.3 The sprayer shall then be inverted for five minutes.

7.6 Nozzle performance

7.6.1 General

This is carried out to evaluate the performance of the nozzle such as the discharge and spray distribution pattern.

7.6.2 Discharge test

7.6.2.1 Discharge in liters shall be measured using the graduated cylinder at the maximum and minimum pressures stated by the manufacturer and two other intermediate pressures for a duration of one minute. In case the manufacturer does not indicate the maximum and minimum pressures to be used, rated operating pressure of the sprayer shall be used.

7.6.2.2 There shall be a minimum of five observations for each data obtained.

7.6.3 Spray angle determination

7.6.3.1 The spray angle is the opening angle which the nozzle jet of droplets forms at the time when it leaves the nozzle orifice. It is measured by determining the included angle formed by the most outer edges of the spray with vertex at the outlet of the nozzle. The included angle can be measured using protractor or any other angle measuring device.

7.6.3.2 There shall be at least five data or readings obtained.

7.6.4 Measuring spray droplet size

The following are the step-by-step method to measure the spray droplets size of the nozzle:

- a) The test shall be conducted in a space without interferences due to wind. Record the ambient relative humidity and temperature during the test;
- b) The spray target shall include six Water Sensitive Paper (WSP) cards placed in a rigid surface positioned on the ground as in Figure 1;
- c) Set the machine at the manufacturer's recommended pressure and nozzle type before the test. Fill the tank with clean tap water;
- d) The sprayer can be worn by an operator or placed on a surface with its nozzle/s positioned at a height of 1 m.
- e) Start the sprayer by pointing the nozzle/s away from the spray target for 10 s. After which, move the nozzle laterally on the spray target for a short spraying time (about 1 s);
- f) Shortly after spraying, wait for the WSP to dry (1-5 min), then collect the dried spray (WSP) targets and place inside a sealable plastic bag;
- g) Scan each of WSP card and analyze it using an image analysis system or any methods of determining spray droplet size; and
- h) Determine the Volume Median Diameter (VMD) and number and volume of spray droplet per area.

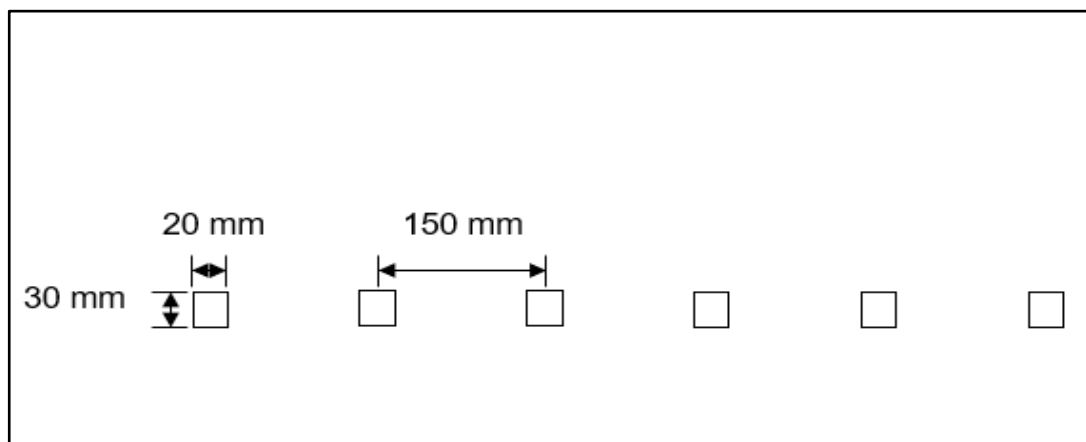

Figure 1. Lay-out of WSP cards (ASABE, 2020)

7.7 Cut-off Valve Reliability

7.7.1 This is carried out to evaluate the strength and durability of the cut-off valve.

7.7.2 Detach the cut-off device assembly with the spray lance from the sprayer and mount it on a frame, as shown in Figure 2.

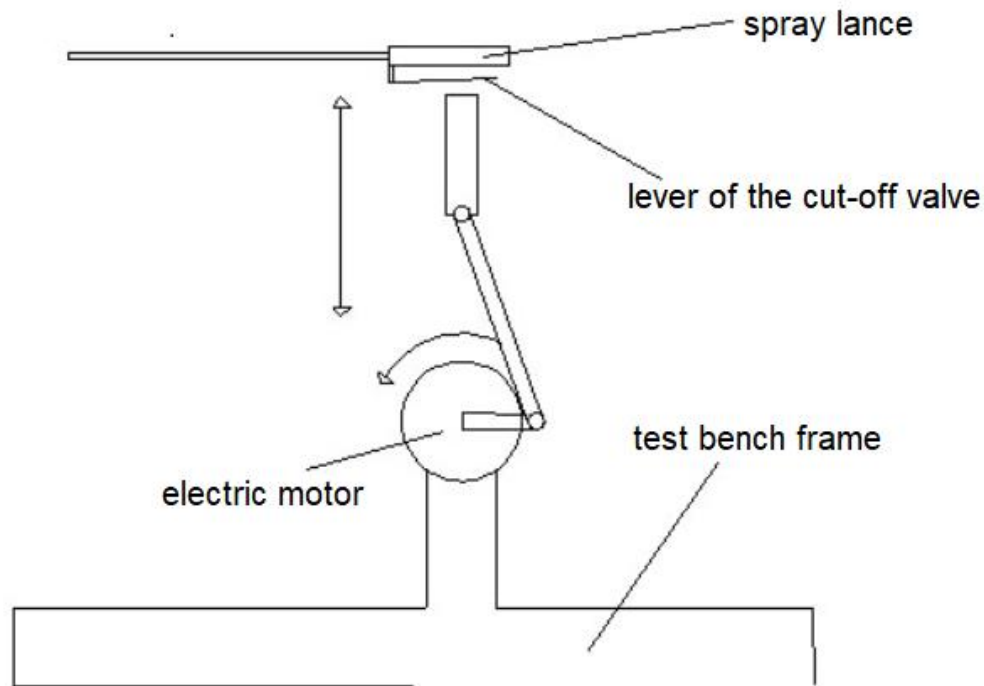

Figure 2. Typical illustration of cut-off valve reliability test device (ISO, 2013)

7.7.3 Cut-off device test equipment, consisting of a frame to fix the hand-held part of the cut-off device and a unit for moving the cut-off device control (e.g., valve lever) to open it periodically with an induced flow at the prescribed rate and pressure. The stroke shall be adjustable, as shown in Figure 2.

7.7.4 Detach the shut-off device assembly with the spray lance from the sprayer and mount it on a frame.

7.7.5 Connect the cut-off device to a pressurized water supply of 300 kPa.

7.7.6 Fully activate the cut-off device using a frequency of 15 cycles/min for a total duration of 25 000 cycles.

7.7.7 Inspect functionality and record any leakage occurring within 1 min after completion of the last cycle.

7.8 Pressure test

7.8.1 Pressure test is carried out to evaluate the strength and durability of the sprayer.

7.8.2 Fill the spray tank with clean tap water to its nominal volume. Connect the outlet of the cut-off device to an external pressure supply device.

7.8.3 Lever-operated, engine-driven, electric motor-driven and dual knapsack sprayers are tested with the spray tank lid removed from the filling opening. Compression sprayers are tested with the spray-tank closed with air pump and lid, if any.

7.8.4 Raise the pressure until the pressure relieve valve opens or the pressure level is two times the rated operating pressure and maintain that pressure for 30 s.

7.8.5 Record the result of the test and the relief valve opening pressure, if applicable.

7.9 Continuous running test

7.9.1 This is carried out to detect any abnormality or trouble resulting from continuous operation.

7.9.2 The sprayer shall be mounted to a specially designed test rig as shown in Figure 3.

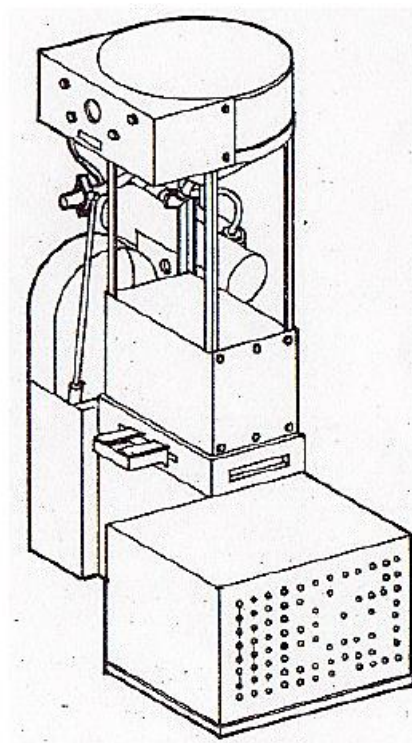

Figure 3. Continuous-running test rig (AMTEC, 2000)

7.9.3 An operating pressure equal to that of the normal working pressure shall be used throughout the test.

7.9.4 A suitable timer for determining total time of operation and a flow meter for measuring the total volume of spray shall be used.

7.9.5 Electric motor-driven knapsack shall run simultaneously along with the battery capacity test. For lever-operated, compression and engine-driven knapsack sprayer, a continuous test for 5 hours shall be conducted.

7.10 Strap

7.10.1 Strap drop test

7.10.1.1 Strap drop test is carried out to assess the durability of the straps.

7.10.1.2 The sprayer shall be filled with clean tap water to its nominal volume and shall be suspended to its straps in a specially designed test rig as shown in Figure 4.

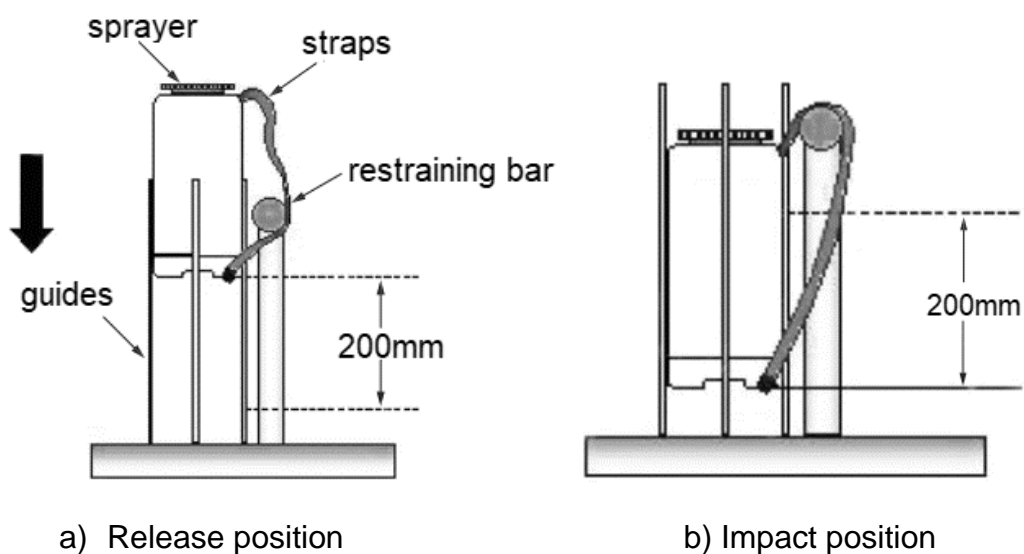

Figure 4. Strap drop test rig in a) release and b) impact positions (ISO, 2013)

7.10.1.3 Attach the sprayer to a strap test device so that each load carrying strap can be tested individually. The sprayer shall be lifted 200 mm from its original position and allowed to drop. Repeat this 10 times for each load carrying strap.

7.10.1.4 Failure or any damage of a part of the straps, strap hangers, or strap clips resulting from the test shall be observed and recorded.

7.10.2 Strap absorbency test

7.10.2.1 This test is carried out to assess the absorbency of carrying straps. It shall be performed at ambient conditions.

7.10.2.2 Remove the carrying straps, and any padding and any metal or plastic parts attached to them before immersion (in order to minimize, as far as possible, the dry mass of the straps) and weigh them dry using a weighing device. Completely immerse the straps in clean tap water for 2 min. Remove the straps from the water, shake off surplus liquid and hang freely to drain for 10 min before re-weighing.

7.10.2.3 Calculate the mass increase in percentage.

7.11 Drop test

7.11.1 Drop test is carried out to assess the durability of the sprayer tank to withstand accidental dropping.

7.11.2 This test shall be carried out on a complete sprayer with all parts and accessories, that is fully completely empty at the start of the test.

7.11.3 Fill the spray tank to its nominal volume with clean tap water. Attach the sprayer to the drop test device as shown on Figure 5. Drop the sprayer once from a height (h) of 600 mm.

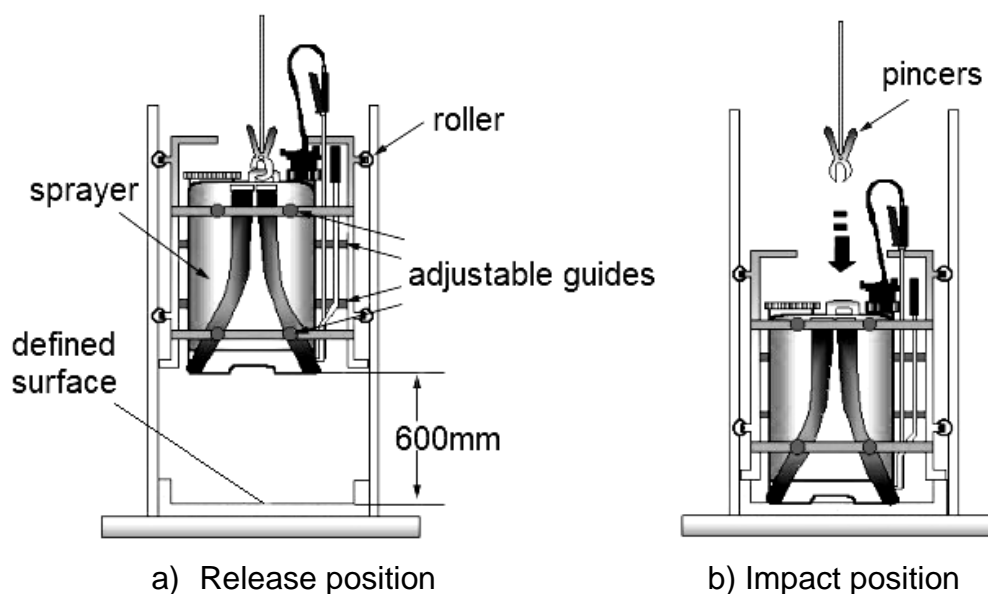

Figure 5. Drop test rig in a) release and b) impact positions (ISO, 2013)

7.11.4 Any form of failure or damage of any part of the sprayer shall be noted.

7.11.5 The items to be measured, inspected, and evaluated under the laboratory test shall be recorded in Annex C (Performance test data sheet).

7.12 Ease of operation

7.12.1 Ease of operation is carried out to evaluate the ease of using the sprayer.

7.12.2 Two operators shall operate and evaluate the sprayer.

7.12.3 The sprayer shall be evaluated according to the following:

- a) Accessibility and ease of actuating pump handle;
- b) Ease of actuating the cut-off device;
- c) Ease of dismantling, assembly, and maintenance of the sprayer;
- d) Ease of filling and cleaning the tank; and
- e) Convenience in fixing the straps and provisions for adjusting strap length.

7.12.4 Physical workload/energy expenditures in operating the sprayer shall be assessed by taking the pulse rate/blood pressure of the operator before and after each operation.

7.13 Operators' safety

7.13.1 This is carried out to assess the safety of the operator in using the sprayer.

7.13.2 The sprayer shall be subjected to different safety tests such as the following:

7.13.2.1 Liquid spillage test

The sprayer filled with clean tap water shall be operated. While pumping, observation shall be made if liquid spills out at the cylinder cap. The operator shall be instructed to bend over while carrying the sprayer. Observation shall be made if the liquid spills out at the tank filler cap and cylinder cap.

7.13.2.2 Liquid dripping test

The sprayer filled with liquid shall be pumped to working pressure recommended by the manufacturer. Observation shall be made if liquid is dripping on the cut-off valve, lance, and nozzle connections.

7.13.2.3 Conformity to the back of the operator

Observations shall be made if the spray tank design is adequate enough to conform to the back of the operator.

7.13.2.4 Tank filler cap test

A full capacity sprayer standing on a level surface shall be pushed until it tips over. Observation shall be made if the tank filler cap is removed.

7.13.2.5 Presence of hot surfaces

Observations shall be made if the sprayer's hot parts provided insulation and protection to minimize the possibility of inadvertent contact.

7.13.3 The different components of the sprayer shall be checked regarding any injury that the operator may encounter while using the sprayer.

7.13.4 Items to be measured shall be recorded in Annex C (Performance test data sheet).

7.14 Data recording and observations

Record sheet for all data and information during the test is given in Annex C (Performance test data sheet). Observations to be taken during the performance test should be recorded in this sheet.

8 Presentation of Results

The sprayer specifications and the results of the test shall be presented in tabular form in which data shall be taken from Annexes B (Specifications of knapsack sprayer) and C (Performance test data sheet). Observations made on the knapsack sprayer while in operation shall be supported with photographs.

9 Formula

The formula to be used during calculations and testing are given in Annex D (Formulas used during calculations and testing).

10 Test Report

The test report shall include the following information in the order given:

- a) Name of testing agency;
- b) Test report number;
- c) Title;
- d) Summary of results;
- e) Observations;
- f) Purpose and scope of test;
- g) Methods of test;

- h) Description of the machine;
- i) Specifications;
- j) Results;
- k) Observations (include pictures); and
- l) Names, signatures, and designation of test engineers.

Annex A
(Informative)

Minimum laboratory test equipment and materials

No.	Equipment	Quantity
A.1	Laboratory test	
A.1.1	Tachometer (pulse and laser)	1
A.1.2	Timers Maximum resolution: 0.1 s	1
A.1.3	Measuring tape (minimum: 3 m)	2
A.1.4	Sound level meter Range: 30 to 130 db(a)	1
A.1.5	Weighing scale Minimum capacity: 100 kg; maximum scale divisions: 0.2 kg	1
A.1.6	Graduated cylinder (for engines) (500-ml capacity) Or clamp-on type power meter (for electric motors)	1
A.1.7	Digital camera	1
A.1.8	Pressure gauge (47.57kpa \pm 1%)	1
A.1.9	Cut-off test device	1
A.1.10	Continuous-running test rig	1
A.1.11	Strap drop test rig	1
A.1.12	Drop test rig	1
A.1.13	Thermometer	1
A.1.14	Protractor	1
A.1.15	Laptop/ computer	1
A.2	Materials	
A.2.1	Clean tap water	
A.2.2	Water Sensitive Paper (WSP) cards	

Annex B
 (Normative)

Specifications of knapsack sprayer

Name of Applicant : _____
 Address : _____
 Tel. No. : _____

Name of Manufacturer : _____
 Address : _____
 Tel. No. : _____

GENERAL INFORMATION

Make : _____ Type : _____
 Serial No. : _____ Brand/Model : _____
 Date of Manufacture : _____
 Testing Agency : _____ Test Engineer : _____
 Location of Test : _____ Date of Test : _____

No.	Items	Manufacturer's specification	Verification by the testing agency
1	Dimension (in transport position including handle and lance)		
1.1	Length, mm		
1.2	Width, mm		
1.3	Height, mm		
2	Weight, kg		
2.1	Without water		
2.2	With water (tank capacity)		
3	Working pressure, kPa		
3.1	Normal		
3.2	Maximum		
4	Tank		
4.1	Volume, L		
4.1.1	Nominal		
4.1.2	Total		
4.2	Dimension, mm		
4.2.1	Length		
4.2.2	Width		
4.2.3	Height		
4.3	Diameter of filler hole, mm		

No.	Items	Manufacturer's specification	Verification by the testing agency
4.4	Material		
5	Piston assembly		
5.1	Length of stroke, mm		
5.2	Diameter, mm		
5.2.1	Piston head		
5.2.2	Cylinder		
5.3	Material		
5.3.1	Piston head		
5.3.2	Cylinder		
5.3.3	Push rod		
6	Pressure chamber		
6.1	Volume, L		
6.2	Shape		
6.3	Location		
6.4	Material		
7	Lever		
7.1	Length, mm		
7.2	Stroke, mm		
7.3	Location		
7.4	Material		
8	Cut-off valve		
8.1	Type		
8.2	Material		
8.3	Lock-on and lock-off feature		
9	Delivery Hose		
9.1	Length, mm		
9.2	Inside diameter, mm		
9.3	Thickness, mm		
9.4	Clamping device		
9.5	Material		
10	Lance		
10.1	Shape		
10.2	Length, mm		
10.3	Inside diameter, mm		
10.4	Material		
11	Grip (lance)		
11.1	Shape		
11.2	Size, Dia. x Length, mm		
11.3	Material		

No.	Items	Manufacturer's specification	Verification by the testing agency
12	Nozzle		
12.1	Type		
12.2	Material		
13	Strainer/Filter		
13.1	Filler hole strainer		
13.1.1	Size of mesh, hole/cm ²		
13.1.2	Materials		
13.2	Inlet-strainer (pump)		
13.2.1	Size of mesh, hole/cm ²		
13.2.2	Materials		
13.3	In-line filter (lance)		
13.3.1	Size of mesh, hole/cm ²		
13.3.2	Materials		
13.4	Nozzle filter		
13.4.1	Size of mesh, hole/cm ²		
13.4.2	Materials		
14	Straps		
14.1	Material		
14.2	Dimension		
14.2.1	Length, m		
14.2.2	Width, m		
14.2.3	Thickness, m		

Annex C
 (Normative)

Performance test data sheet

1 Volumetric efficiency

Items	Trials					Ave.
	1	2	3	4	5	
Method of operating the lever						
Rated operating pressure, kPa						
Number of strokes						
Discharge, L						
Volume discharge/stroke, L						
Piston displacement, L						
Volumetric efficiency, %						

2 Leak test

Trials	Pressure applied, kPa	Duration, min	Final pressure, kPa	Pressure drop, kPa
1				
2				
3				
Ave.				

3 Tilt and inversion tests

Position	Observation

4 Nozzle performance test

4.1 Nozzle discharge test

Pressure, kPa	Duration min	Trials, mL					
		1	2	3	4	5	Ave.

4.2 Nozzle spray angle determination

Trials	Angle, °
1	
2	
3	
4	
5	
Ave.	

4.3 Measuring of spray droplets size

Ambient condition

Temperature: _____

Relative humidity: _____

WSP position	VMD, μm	Droplet distribution, spray droplets/cm ²	Deposition, $\mu\text{L}/\text{cm}^2$	Spray quality ¹
1				
2				
3				
4				
5				
6				

¹ American Society of Agricultural and Biological Engineers (ASABE). (2020). Droplet size classification (ASABE S-572.1).

5 Cut- off valve reliability test

Trials	Pressure applied, kPa	Duration, min	Observations
1			
2			
3			
Ave.			

6 Pressure test

Operating pressure, kPa	Duration pressure cycles	Observations

7 Continuous running test

Operating pressure, kPa	Total time elapsed, h	Observations

8 Strap drop test

Height of lift, mm	No. of times dropped	Observations

9 Strap absorbency test

Ambient condition

Temperature: _____

Relative humidity: _____

Initial Weight, g	Final Weight, g	Absorbency rate, %

10 Drop test observations

11 Observations

11.1 Position and shape of lever (if any) and fatigue in operation

11.2 Ease of manipulating of cut-off device

11.3 Ease of disassembly or assembly and maintenance

11.4 Spillage at the tank filler cap and cylinder cap

11.5 Dripping on the cut-off valve, lance and nozzle connections

11.6 Conformity to the back of the operator

11.7 Tank filler cap test

11.8 Presence of hot surfaces

11.9 Other comments (including constructional observations)

Annex D
(Normative)

Formulas used during calculations and testing

D.1 Piston displacement determination

$$D_p = \frac{Al}{1000} \quad (1)$$

$$A = \frac{\pi d^2}{4} \quad (2)$$

where:

D_p is the piston displacement, L
 A is the cross-sectional area of the cylinder, cm²
 D is the diameter of the cylinder, cm
 l is the length of actual piston travel, cm

D.2 Volumetric efficiency

$$V_{eff} = \frac{V_a}{D_p} \times 100$$

where: V_{eff} is the volumetric efficiency, %
 V_a is the actual volume discharge, L
 D_p is the piston displacement, L

D.3 Strap absorbency test

$$\Delta m = \frac{m_a - m_b}{m_b} \times 100$$

where: Δm is the absorbency rate, %
 m_b is the mass before the test, g
 m_a is the mass after the test, g

Bibliography

- American Spring & Pressing Works Pvt. Ltd. (ASPEE). (1991). Workshop on small sprayer standards, safety and future directions held in Bombay, India.
- Agricultural Machinery Testing and Evaluation Center (AMTEC). (2000). Agricultural machinery — Lever-operated knapsack sprayer — Methods of test (PAES 113:2000).
<https://amtec.ceat.uplb.edu.ph/wp-content/uploads/2019/07/PAES-113-2000.pdf>
- AMTEC - UPLB. (2000). Agricultural machinery — Method of sampling (PAES 103:2000). <https://amtec.ceat.uplb.edu.ph/wp-content/uploads/2019/07/PAES-103-2000-Agricultural-Machinery-Method-of-Sampling.pdf>
- Agricultural Machinery Testing and Evaluation Center (AMTEC) - University of the Philippines Los Baños (UPLB). (2022). Test reports for agricultural machinery — Knapsack sprayer (2016 – 2021).
- American Society of Agricultural and Biological Engineers (ASABE). (2020). Droplet size classification (ASABE S572.1).
https://cdn2.hubspot.net/hub/95784/file-32015844-pdf/docs/asabe_s572.1_droplet_size_classification.pdf
- Bureau of Agriculture and Fisheries Standards (BAFS) - Department of Agriculture (DA). (2022). Agricultural and fisheries machinery — Knapsack sprayer — Specifications (PNS/BAFS 331:2022).
- International Organization for Standardization (ISO). (2013). Equipment for crop protection — Knapsack sprayers — Part 2: Test methods. (ISO 19932-2:2013)
- Sutherland, J.A. (1987). Procedures for the comparative evaluation of knapsack sprayer. Natural Resources Institute.

Department of Agriculture (DA)

Bureau of Agriculture and Fisheries Standards (BAFS)

**Technical Working Group (TWG) for the Philippine National Standards (PNS)
on Knapsack Sprayer – Specifications and Methods of Test**

Chairperson

Eusebio, Romulo, ABE
Agricultural Machinery Testing and Evaluation Center (AMTEC) –
University of the Philippines Los Baños (UPLB)

Vice Chairperson

Lanzuela, Virgilio
Metalworking Industries Association of the Philippines (MIAP)

Members

- | | | | |
|---|--|---|--|
| 1 | Dupla, Ace Philip, ABE | 6 | Paras, Fernando, Jr., PhD
College of Engineering
and Agri-industrial Technology
(CEAT) - UPLB |
| 2 | Salayon, Jennifer, ABE
Bureau of Agricultural and
Fisheries Engineering (BAFE) - DA | 7 | Rodulfo, Victor, Jr., PhD
Center for Agri-Fisheries and
Biosystems Mechanization
(BIOMECH) - UPLB |
| 3 | Casasola, Hezron, ABE
Philippine Council for Agriculture
and Fisheries (PCAF) - DA | 8 | Panagsagan, Joel
Agricultural Machinery
Manufacturers and Distributors
Association (AMMDA) |
| 4 | Gregorio, Reynaldo, ABE
Philippine Center for Postharvest
Development and Mechanization
(PHilMech) - DA | | |
| 5 | Fajardo, Arthur, PhD
Agoncillo, Mary Christine, ABE
AMTEC - UPLB | | |

BAFS Management Team

Roscom, Karen Kristine
Hernandez, Gari Pellinor, DVM
Villanueva, Joshua, ABE

Advisers

Mamaril, Vivencio, PhD
Mula, Myer, PhD



BUREAU OF AGRICULTURE AND FISHERIES STANDARDS

**BPI Compound Visayas Avenue, Diliman, Quezon City 1101 Philippines
T/ (632) 928-8741 to 64 loc. 3301-3319
E-mail: bafs@da.gov.ph
Website: www.bafs.da.gov.ph**